

ICENES 2007

Linear Pulse Motor Type Control Element Drive Mechanism for the Integral Reactor

2007. 6. 5

JE-YONG YU



한국원자력연구원
Korea Atomic Energy Research Institute

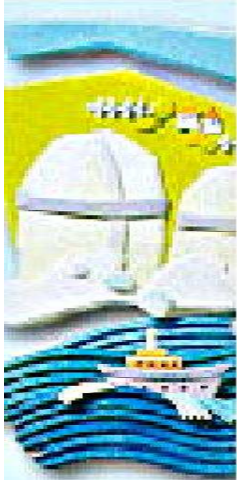

Contents

- Introduction
- System descriptions
 - Linear pulse motor(LPM)
 - Position indicator
 - Damper
 - Extension shaft assembly
- Development of LPM
 - Theory of thrust force
 - Design
 - Manufacturing and test
- Conclusion

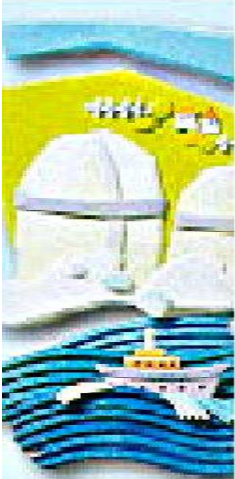

Introduction

■ Background

- Small and Medium Size Integral Reactors are under development at KAERI
- Operation Requirements
 - Soluble boron free operation
 - Use of nuclear heating for reactor start-up
 - Fine-step movement capability as well as high reliability for fine reactivity control

■ Objectives

- Design of CEDM
- Electro-magnetic analysis of LPM
- 3D modeling of LPM and CEDM
- Experiment and calculation for thrust force of LPM

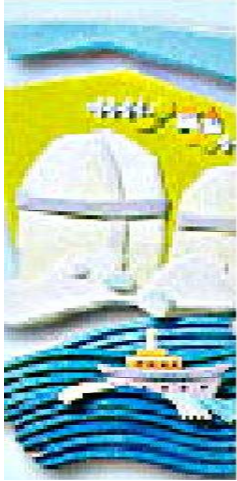

System description

- Linear Pulse Motor (LPM)
 - Simple kinematical scheme
 - High operation reliability
 - Long service life
 - Low Cost
- Position Indicator
 - 4 channel, Resolution : 20mm
 - Using reed switch sensor
- Damper
 - Hydraulic type
 - Coiled compression spring
- Extension Shaft Assembly
 - Link between CEDM armature and CEA

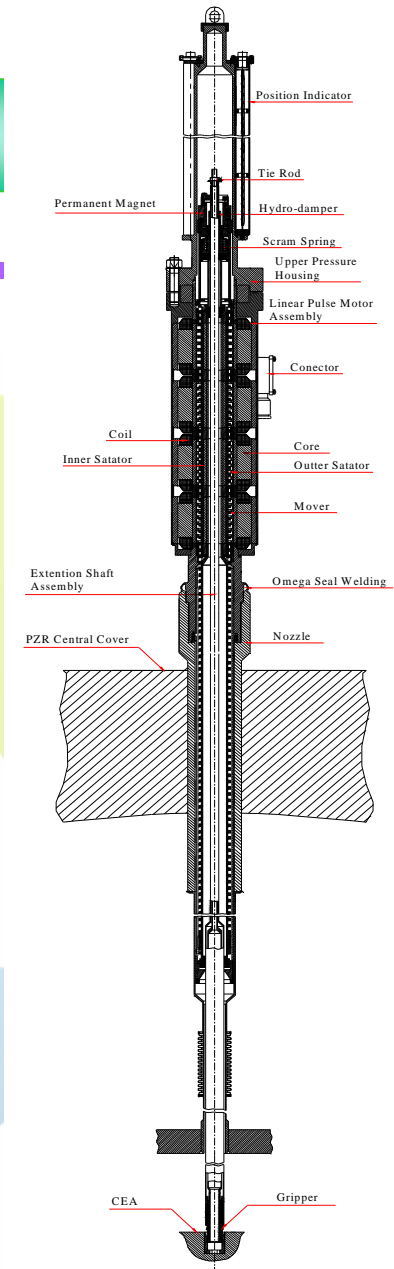

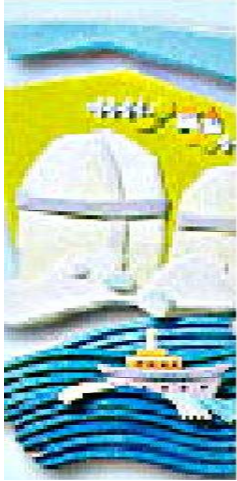

Design requirements of LPM

Items	Value
Total stroke [mm]	2,000
Displacement/pulse [mm]	4.0
Operating speed [mm/sec]	0-50
Load [kg]	100
Holding force [kg]	150
Dynamic thrust force [kg]	100
Air gap [mm]	Less than 0.4
Friction force [kg]	20-30

- Coolant temp. in CEDM : 180 degrees
- Design pressure : 17MPa
- Operating pressure : 15MPa
- Max. Speed : 50mm/sec
- Drop speed at Emergency : 150mm/sec



Linear Pulse Motor (LPM)

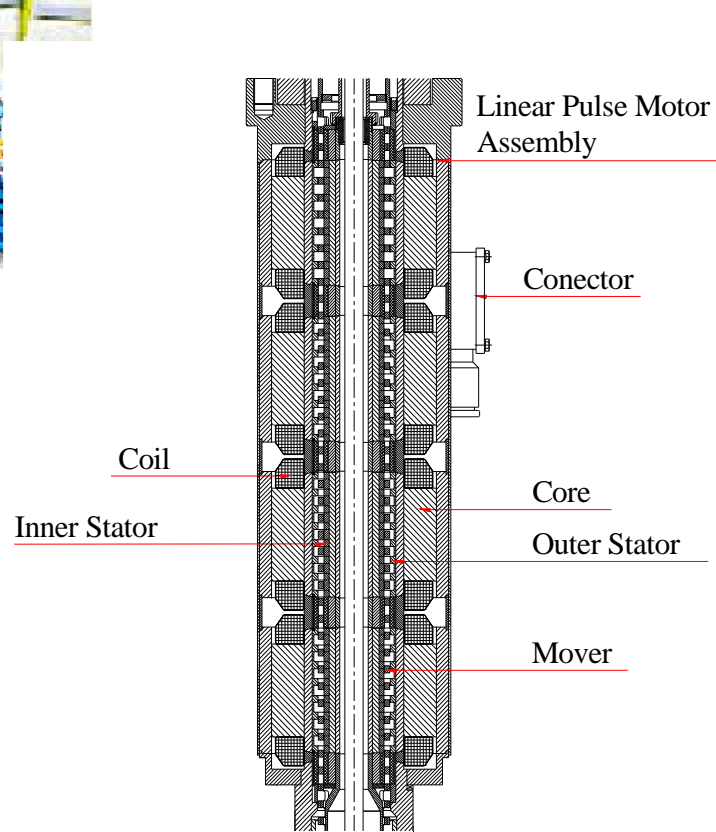

Non-magnetic stainless steel

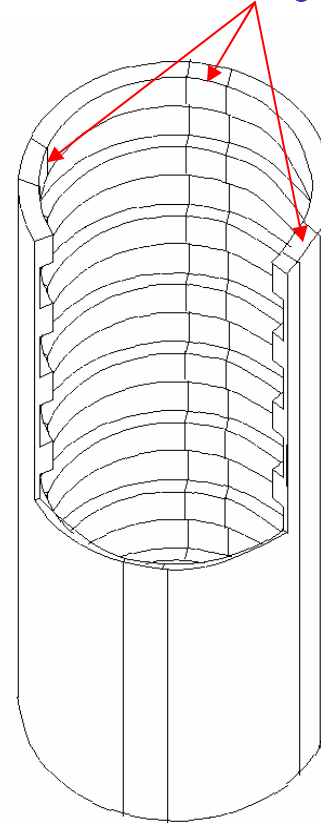

Outer stator of LPM

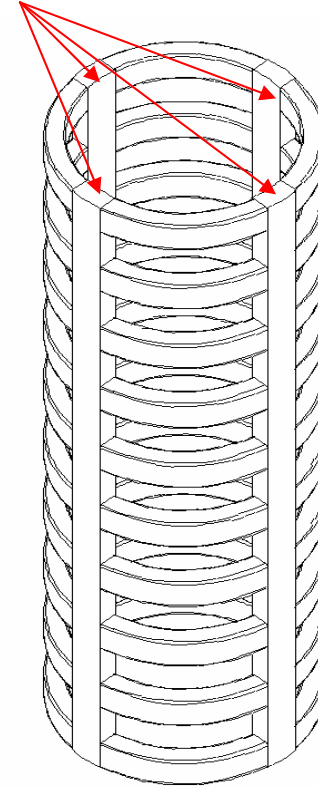

Mover of LPM

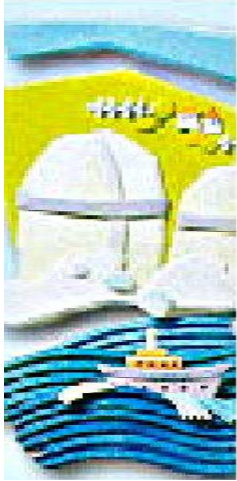

LPM Moving Mechanism

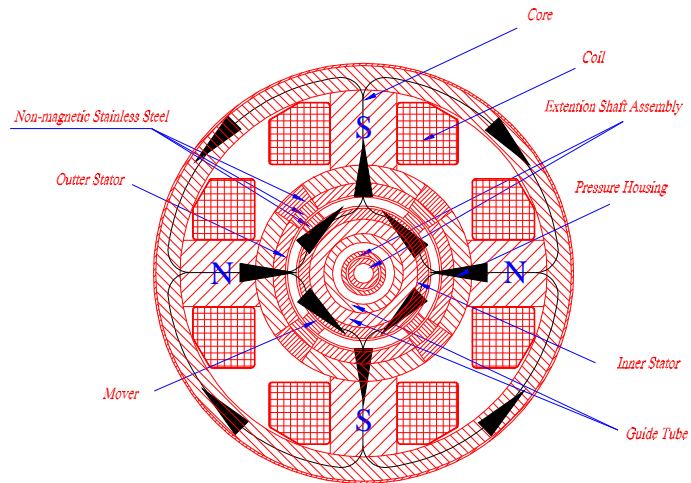

Section view

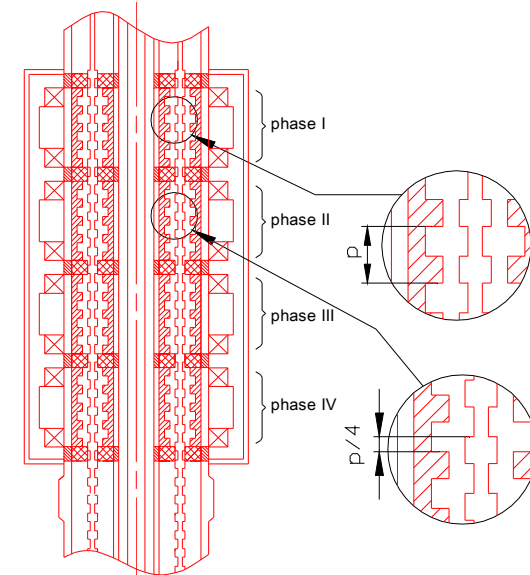

Pitch concept

Up : I-II, II-III, III-IV, IV-I, I-II

Down : I-II, IV-I, III-IV, II-III, I-II

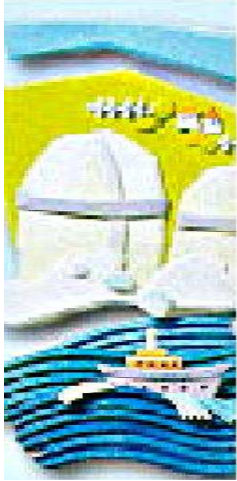

Electro-Magnetic Model

Basic equation for analysis

$$F_{Ax} = \frac{\mu_0}{8\delta\tau} \Theta^2$$

Where

- F_{Ax} : Force density
- μ_0 : Permeability of free space
- δ : Air gap length
- τ : Pole pitch
- Θ : Current

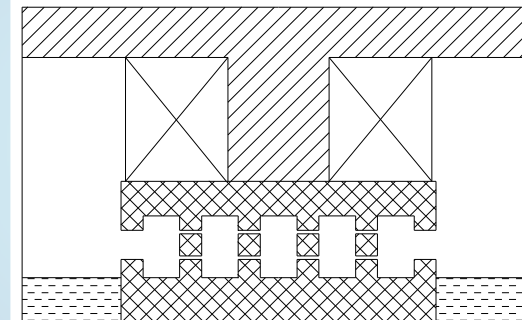
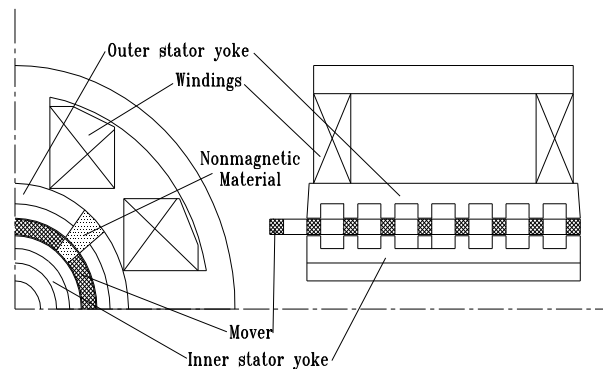

Equivalent 2-dimensional analysis model of LPM

Electro-Magnetic Analysis

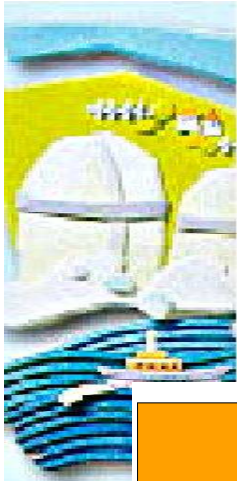

Using Flux2D program

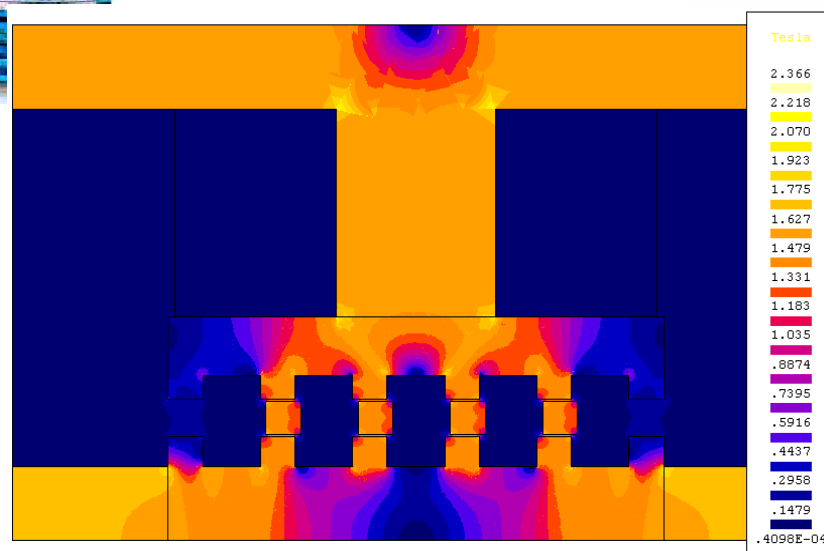

Profile of flux density when displacement of mover is 0.5mm

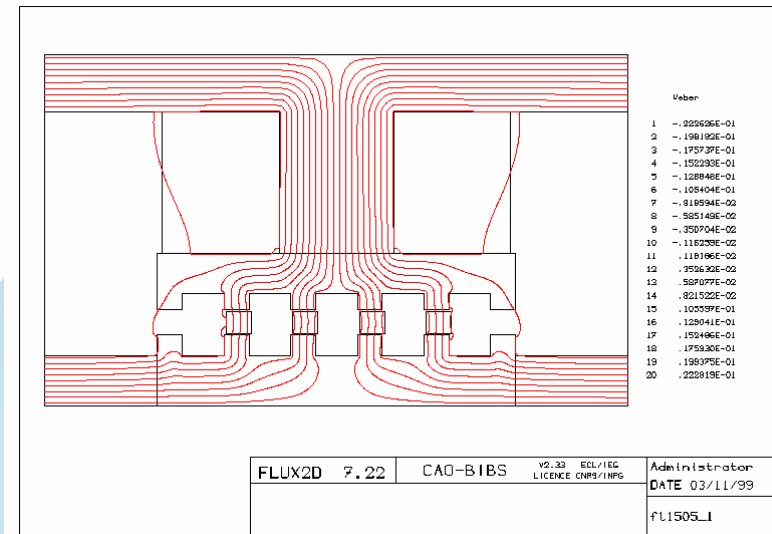

Equi-magnet flux line when displacement of mover is 0.5mm

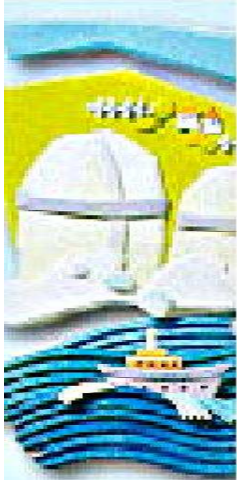

Analytic Results

Mover	Inner radius	59.7 mm
	Outer radius	72.3 mm
	Tooth width	6.0 mm
	Tooth pitch	16.0 mm
	Length	2,200 mm
Outer stator	Inner radius	73.5 mm
	Outer radius	84.0 mm
	Tooth width	6.0 mm
	Tooth height	4.0 mm
	Tooth pitch	16.0 mm
Inner stator	Inner radius	40.0 mm
	Outer radius	59.0 mm
	Tooth width	6.0 mm
	Tooth height	5.0 mm
	Tooth pitch	16.0 mm
Air-gap		0.35*2 mm
Number of phases		2-P bipolar

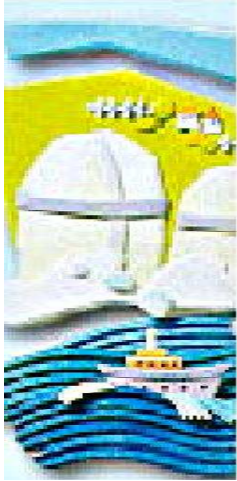

3D CEDM Model

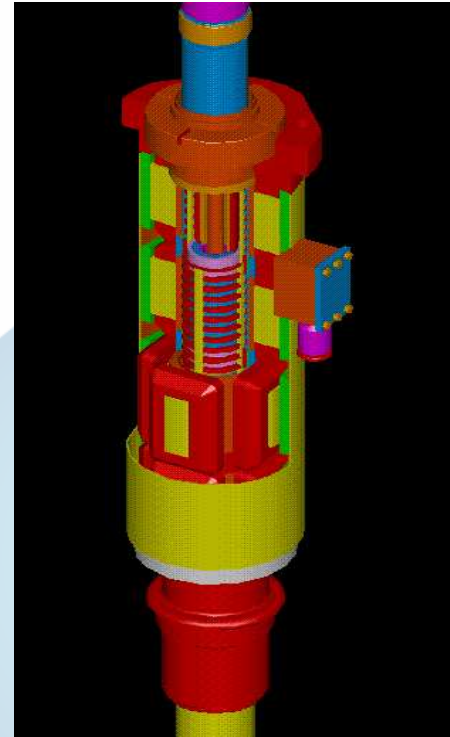
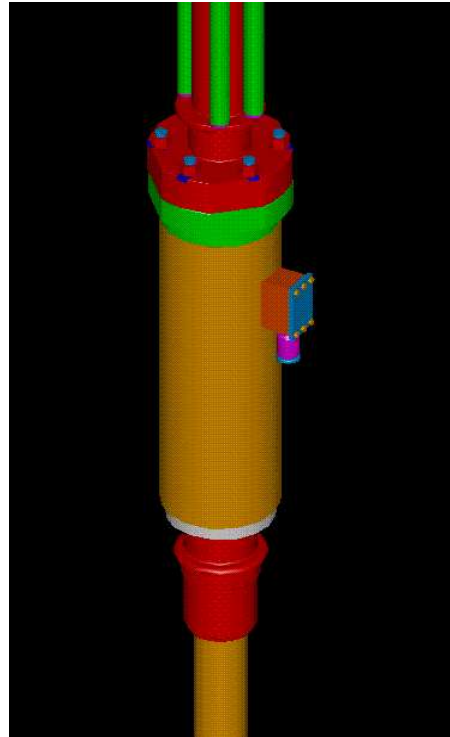

Using I-DEAS program

LPM and Test Facilities



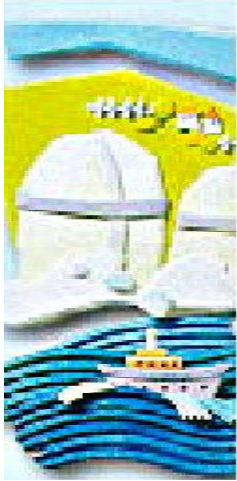

Experimental and Calculated Results

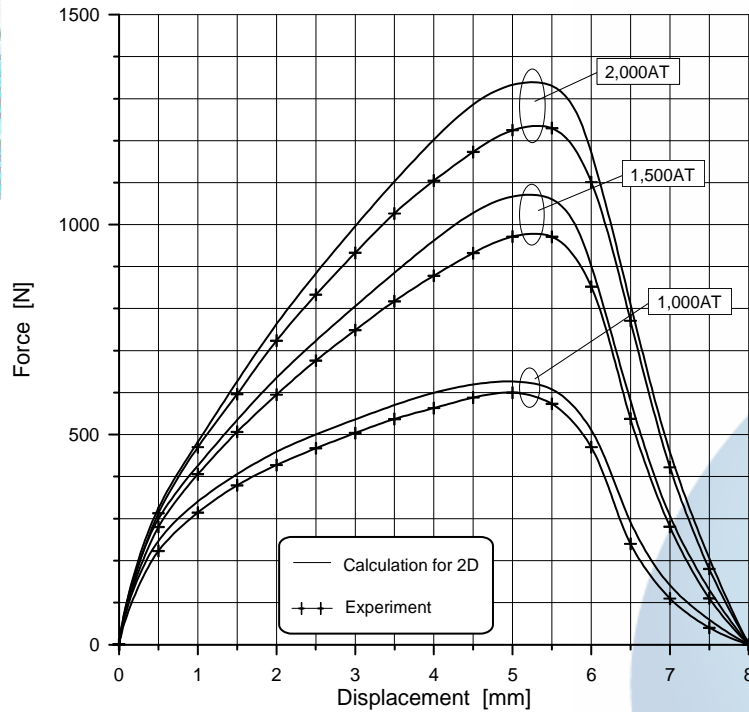

Current [AT]	Experiment [N]	Calculation [N]
1000	602	622
1500	981	1078
2000	1240	1343

Comparison of maximum static thrust forces

Static thrust forces to 1-phase stator coil

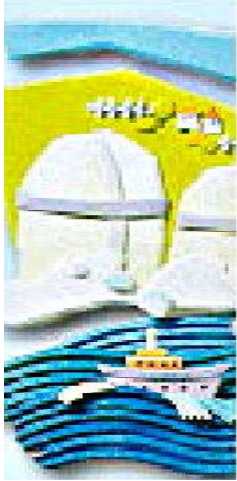

Experimental Results

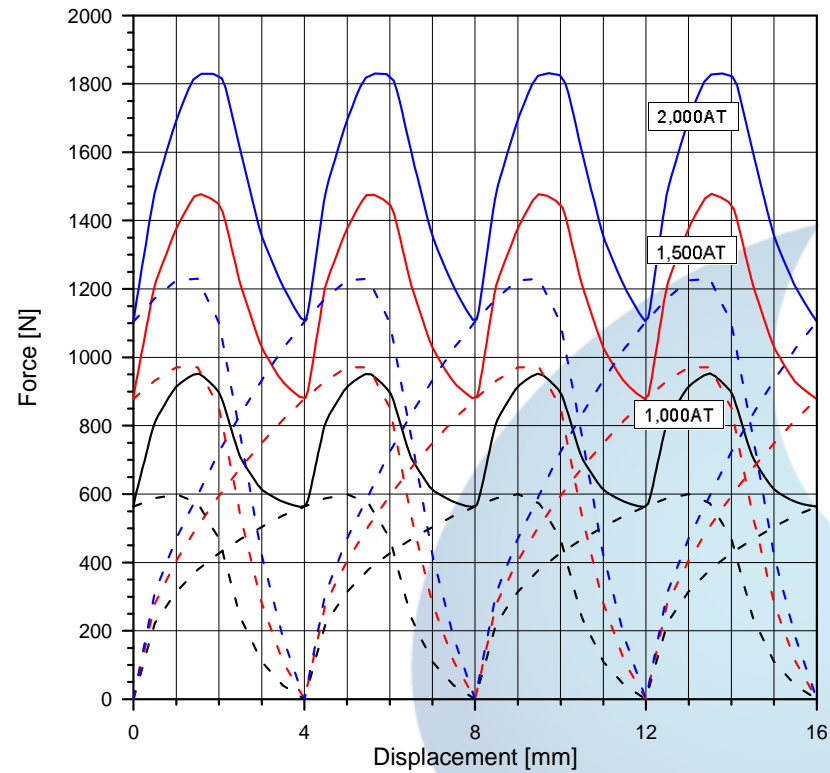

Total thrust forces of LPM with two phase excitation

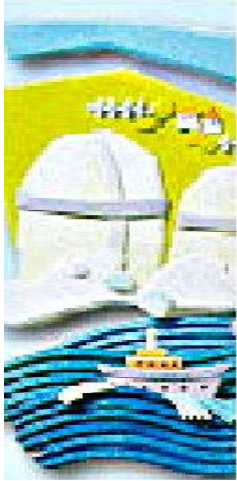

Conclusion

- Realization of LPM type CEDM design concept
- Selection of tooth shapes of stators and mover by magnetic analysis
- Confirmation of manufacturability of CEDM by 3D model
- Confirmation of performance of LPM by magnetic analysis and test
- Developed CEDM can be effectively applied to the integral reactor