

In the Name of God



Conceptual Design of GaN Betavoltaic Battery using in Cardiac Pacemaker

M. Mohamadian, A. Fegghi, H. Afarideh

*Department of Nuclear Science and Physics
Amirkabir University
Iran*





Presentation Outline

- Motivation and Objectives
- Historical Perspective
- Applications
- Pacemaker Basics
- What is a Nuclear Battery?
- Material & Methods
- Simulation & Calculation
- Results & Conclusion
- Future Work



Motivation

- Long half lives of β -radiation sources
- Significant energy density in source
($\sim 10^5$ kJ/m³ in comparison with chemical source
 ~ 10 kJ/m³)
- Low energy sources are relatively benign
 - Small penetration depths
 - More safety
- Stable Voltage and Current
- Higher Efficiency



Objectives

**Determination of the optimal parameters
of low energy
GaN Betavoltaic battery
in artificial Cardiac Pacemakers
using MCNP code
with higher efficiency than those available
with previous devices**

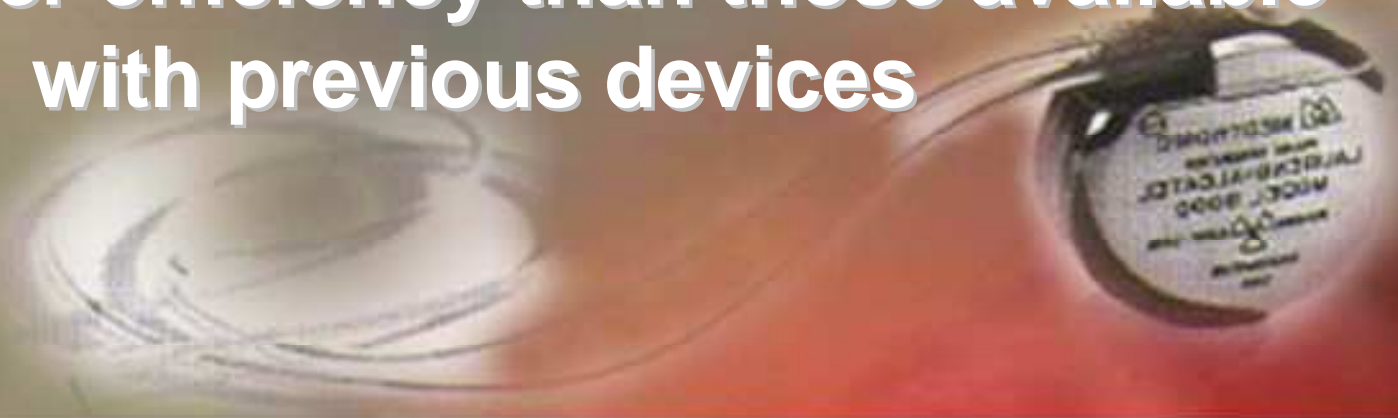



AMTEK LAB TEK
University of Technology

History

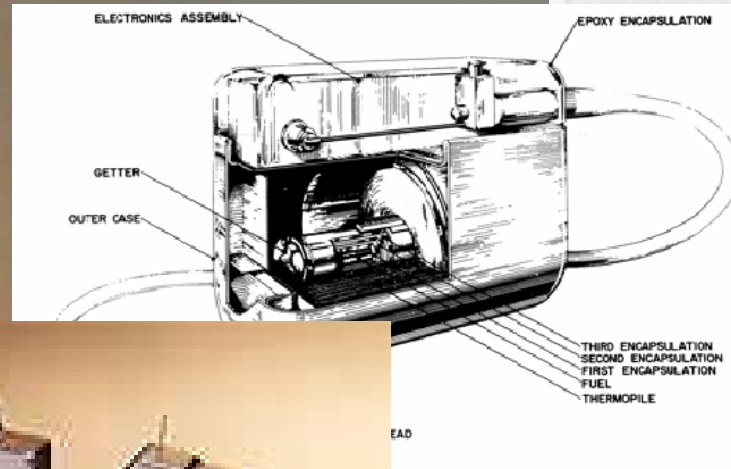
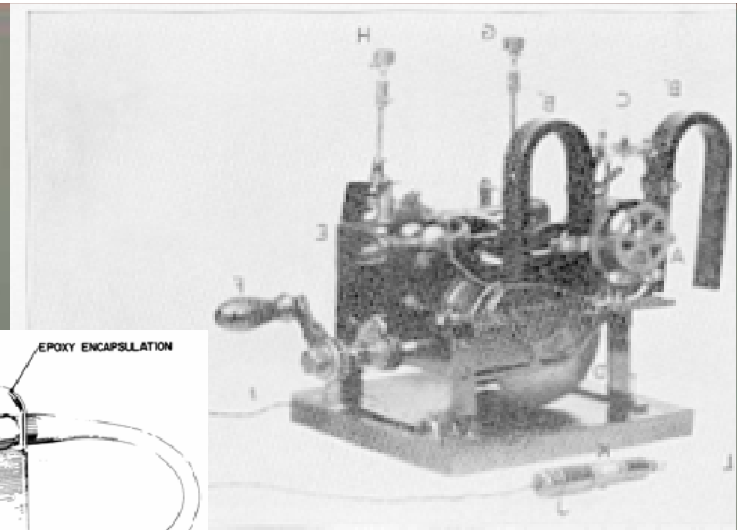

Nuclear Battery

Artificial Pacemaker



Nuclear-Powered Pacemaker

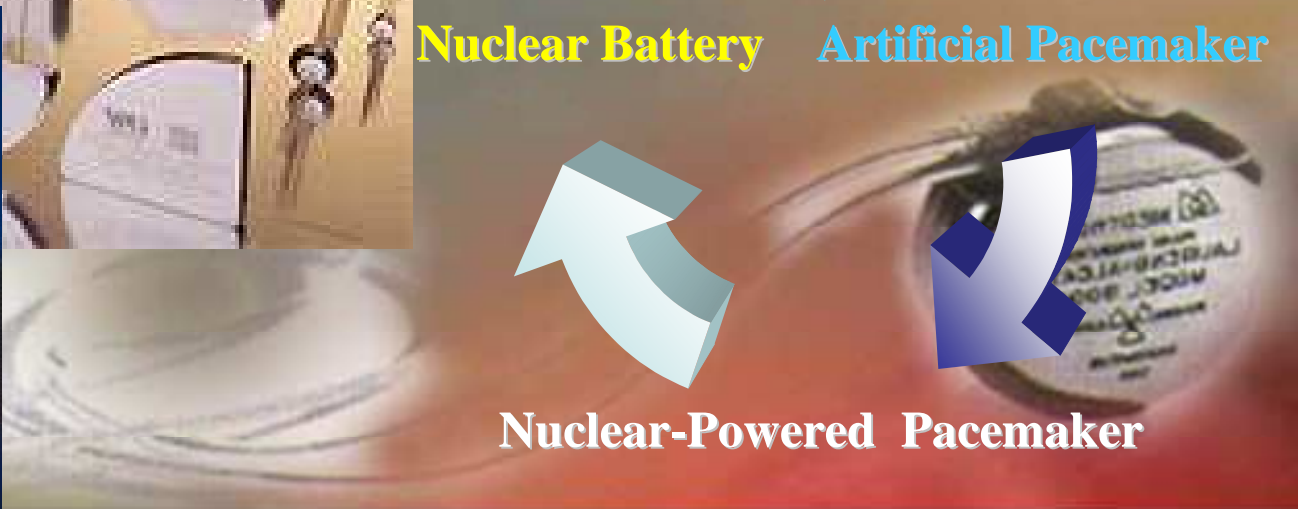
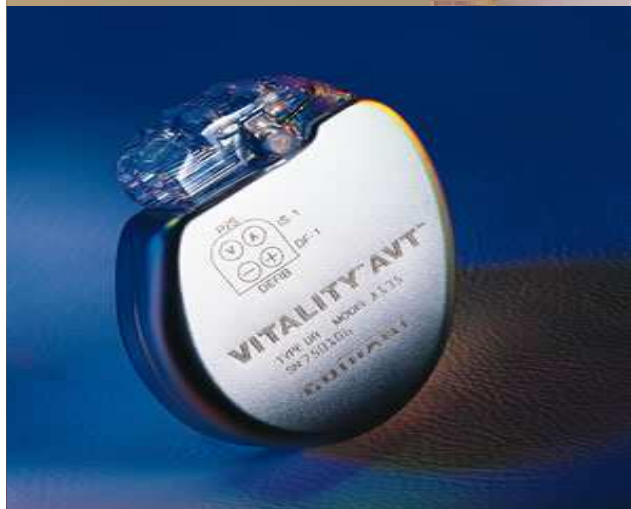

Historical Perspective

- **Artificial Pacemaker was first described in 1930 by Hyman**
- **Nuclear Battery was first invented in 1951 by Philip Edwin Ohmart from Ohio Uni.**
- **Nuclear-Powered Pacemaker was first designed in the late 1960s by Medtronic & Alcatel Co.**
- **The first human implant of the device took place in Paris in 1970**



One of the first pacemaker with Nuclear Battery

- 3 Ci ^{238}Pu
- ~3 ounces
- ~3 inches
- < mW power levels
- 100 mrem/y to patient

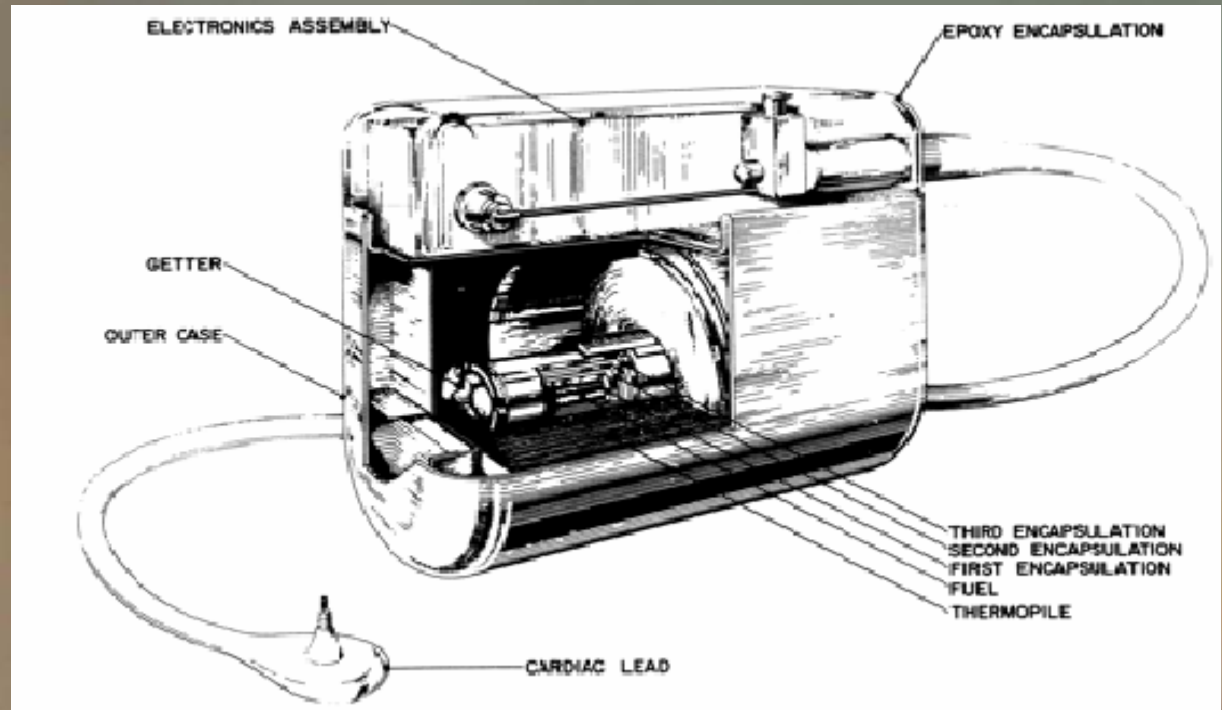

Pacemaker Basics

A pacemaker is a surgically-implanted electronic device that automatically with augment or replace the heart's intrinsic electrical system, regulates a slow or erratic heartbeat.

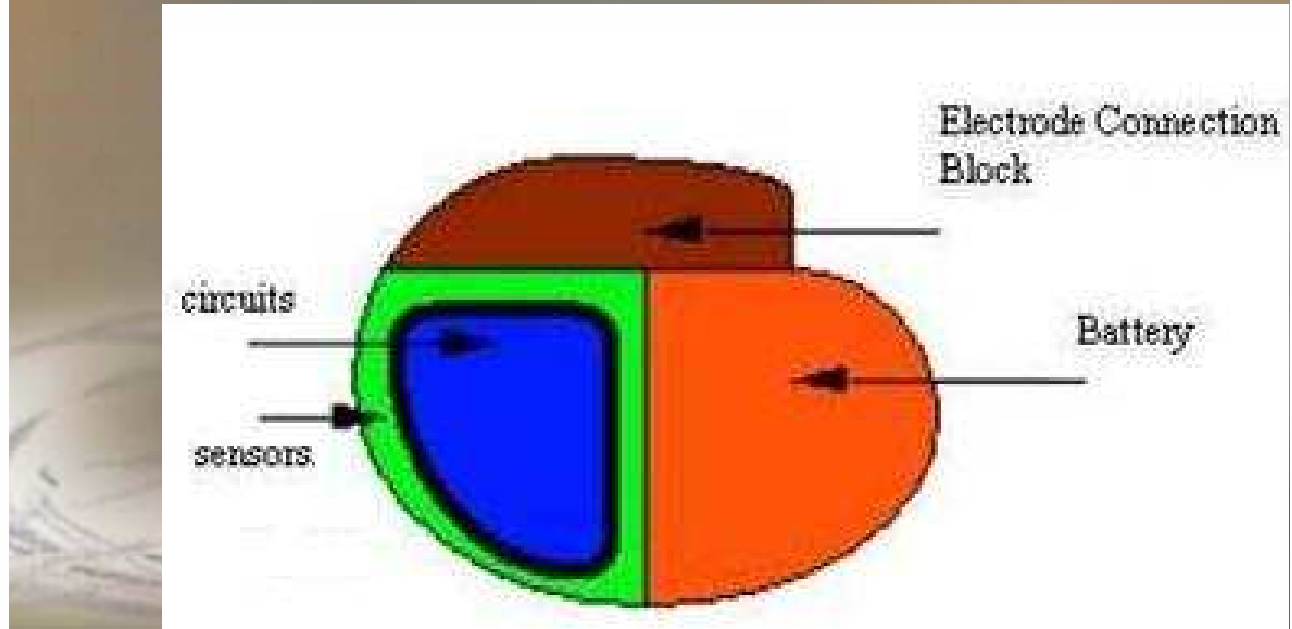
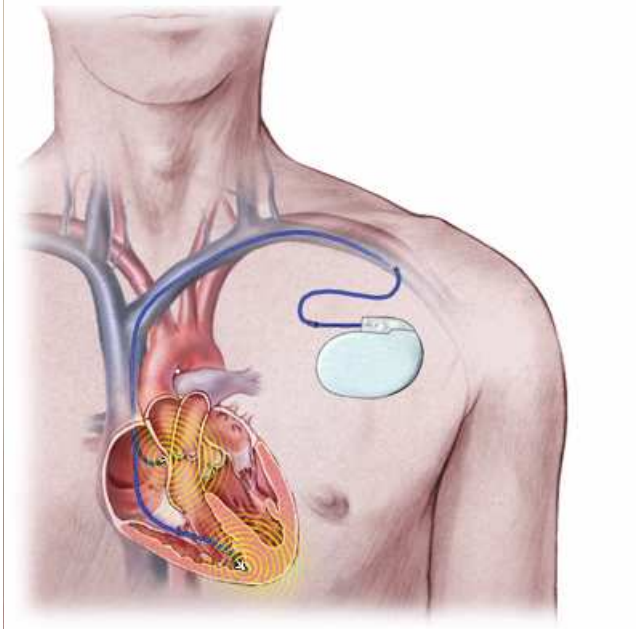

Pacemaker Components

- *Power Source (Battery)*
- *Electronic Circuitry (Pulse Generator)*
- *Lead system*

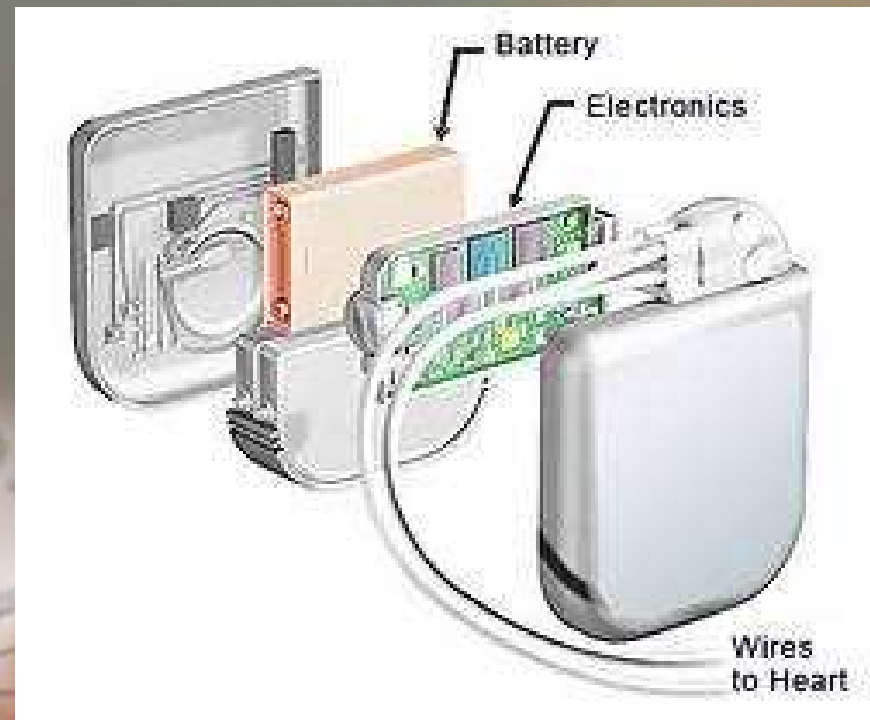

Pacemaker Diagram

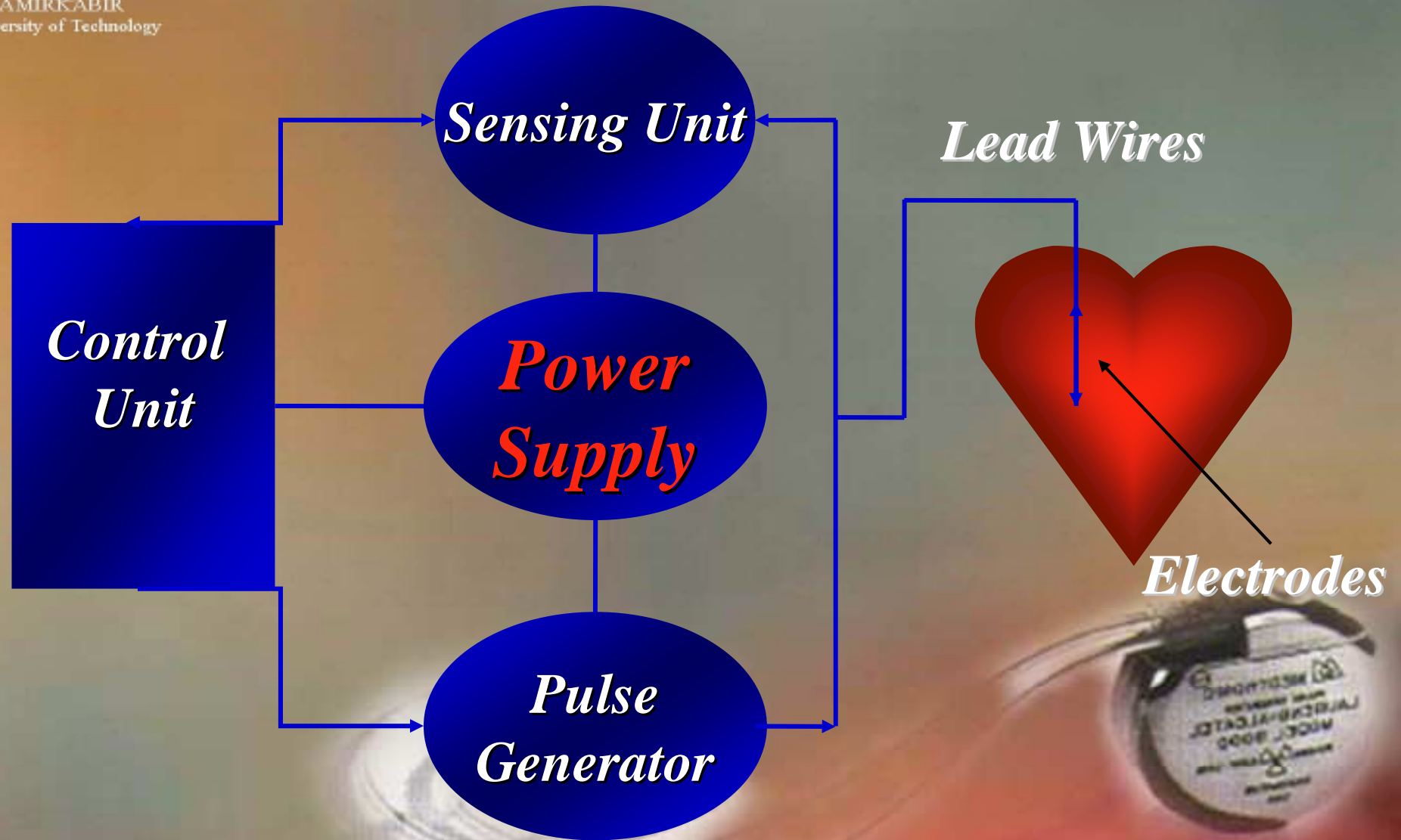



Power Source (Battery)

- External power
- Fuel Cells
- Chemical Batteries
- Fossil Fuels
- Radioisotopes



Pacemaker Generators

Medscape®

www.medscape.com

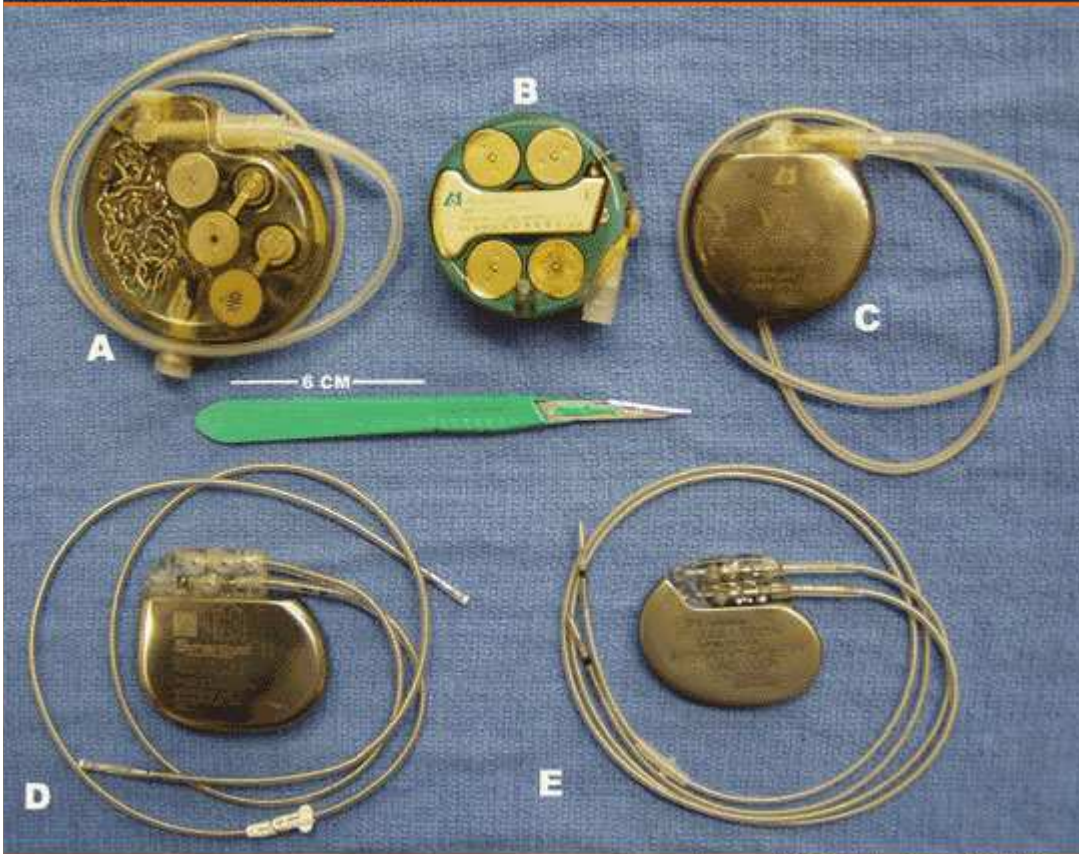

Source: ACP Medicine © 2004 WebMD Inc.

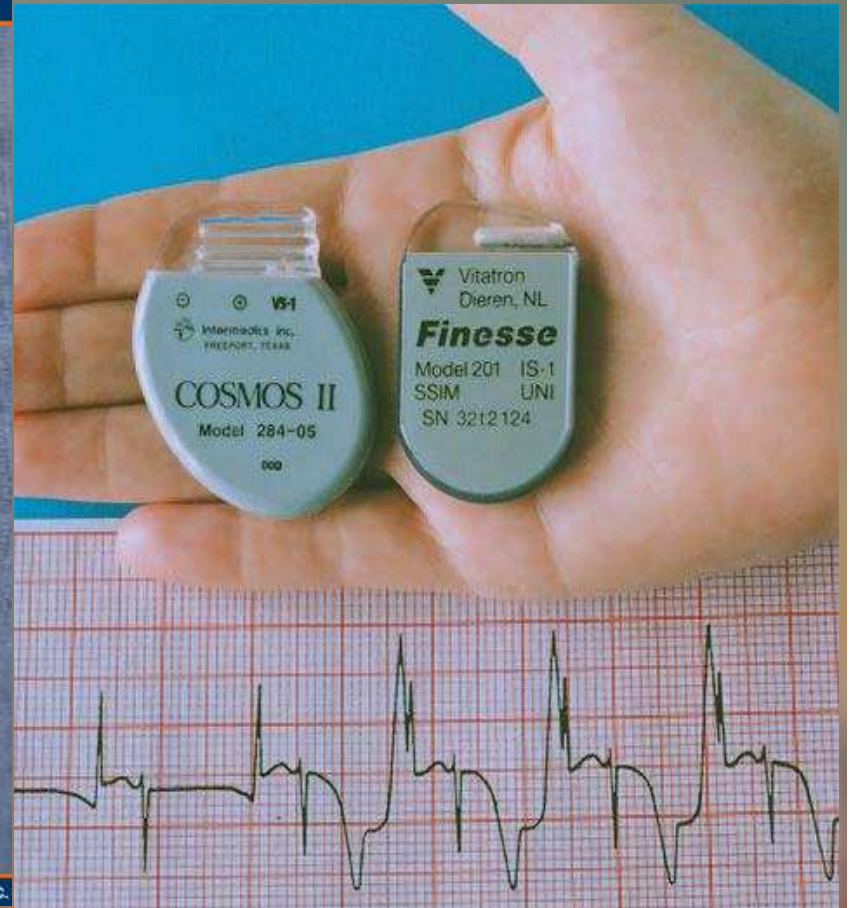



Power Source (Battery)

Most commonly lithium-iodide cell which is the current standard battery

Life span 5 to 8 years

Output voltage decreases gradually with time

Makes sudden battery failure unlikely





Power Source (Battery)

Using Radioisotopes in Nuclear Batteries

- provide reliable and stable power
- Many of the conversion technologies can function in harsh environments
- They are valuable when long life is needed



What happen in Nuclear Battery?

**Converter of energy from radioactive
decay to electricity**

- **Options:**
 - **Direct charge collection**
 - **Betavoltaic**
 - **Thermoelectric**
 - **Thermionic**
 - **thermophotovoltaic**



Direct conversion Nuclear Battery

Direct charge collection

collecting charges emitted from radioisotopes with a capacitor to achieve high voltage output (J. H. Coleman, 1953)

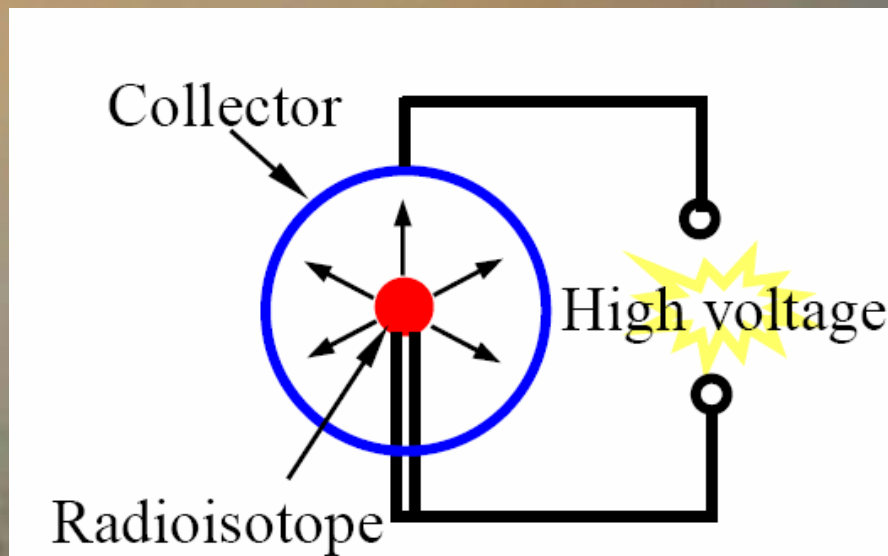

$$V = \frac{Q}{C}$$

10-100 kV voltages can be created in vacuum



Thermoelectric

The thermoelectric method for *conversion of thermal energy to electricity* is based on the thermoelectromotive force arising from temperature gradient between two branches of an electric circuit composed of different conductors or semiconductors.

Each thermocouple is formed by the junction of two dissimilar materials, one of which is heated and the other cooled.

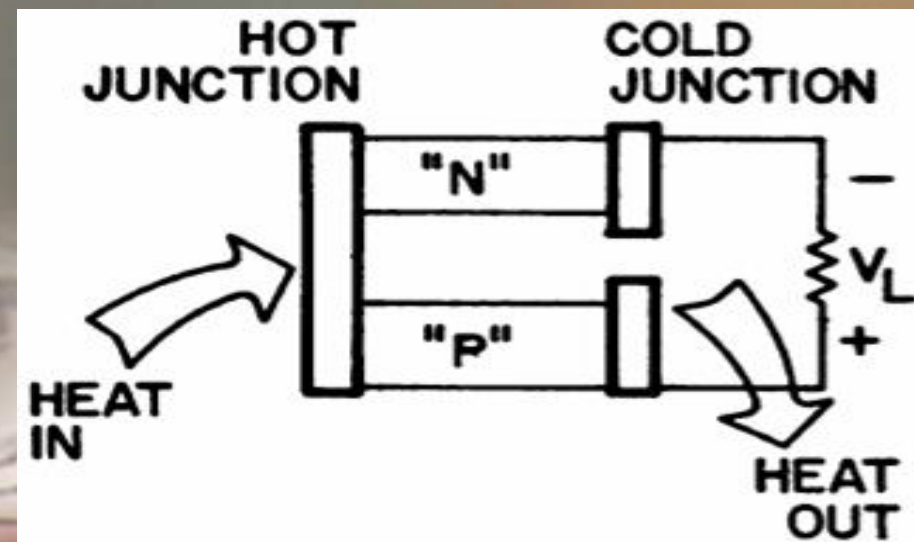

Thermionic

The thermionic method for *conversion of thermal energy to electricity* is based on the thermo electron emission phenomenon.

A thermionic converter, consists of a hot electrode which thermionically emits electrons over a space charge barrier to a cooler electrode, producing a useful power output.

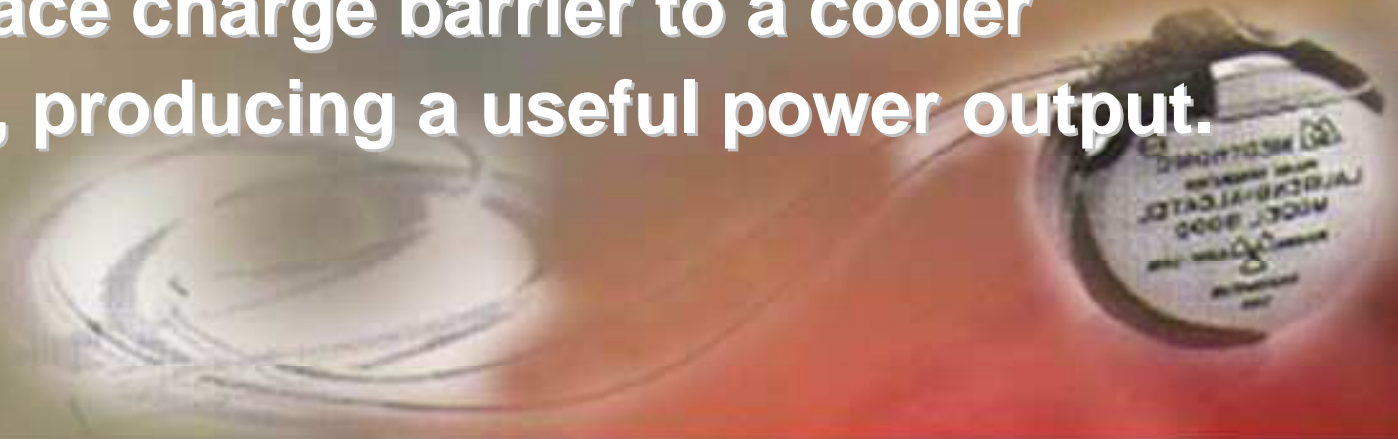

Thermionic

When heated to a high temperature (up to 1700C), a cathode emits electrons that pass through alkali metal (cesium) vapor and are collected on an anode kept at a considerably lower temperature (up to 700C)

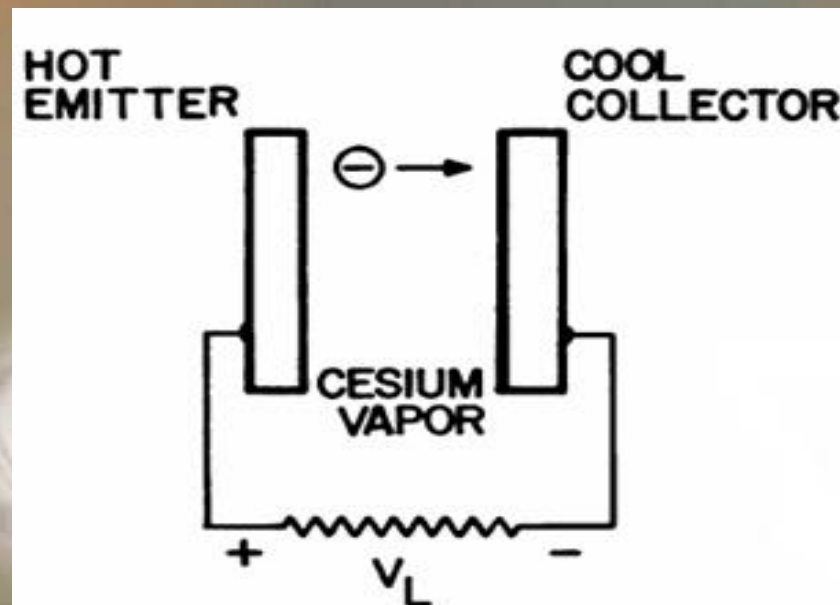

Both thermionic and thermoelectric converters have been evaluated for pacemaker application.



CARDIAC PACEMAKER POWER SOURCES

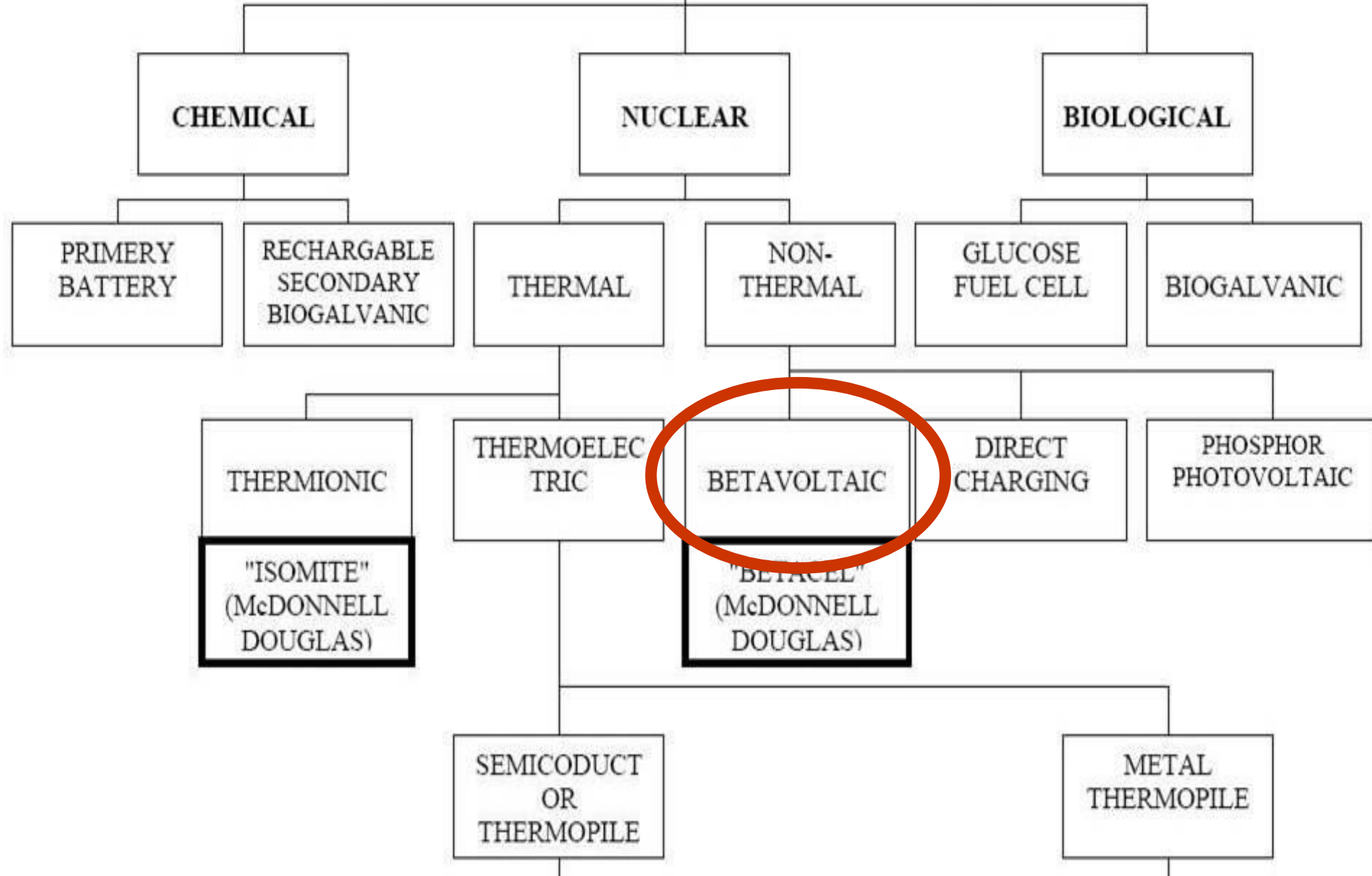

Review theory of Betavoltaic Cell Operation



Betavoltaic Construction

A Betavoltaic device consists;
semiconductor as a p-n junction
beta emitter isotope

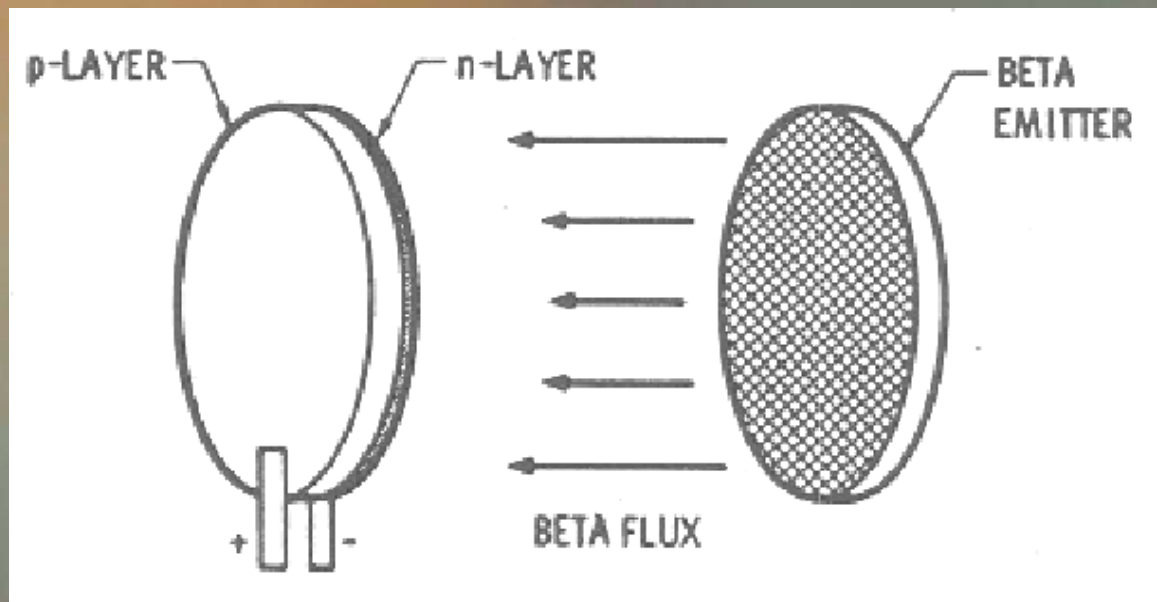

Betavoltaic Construction

The Betavoltaic devices are based on separation of the electron-hole pairs originating on exposure of semiconductor material by an electric field created by p and n layers of the p-n or p-i-n junctions .

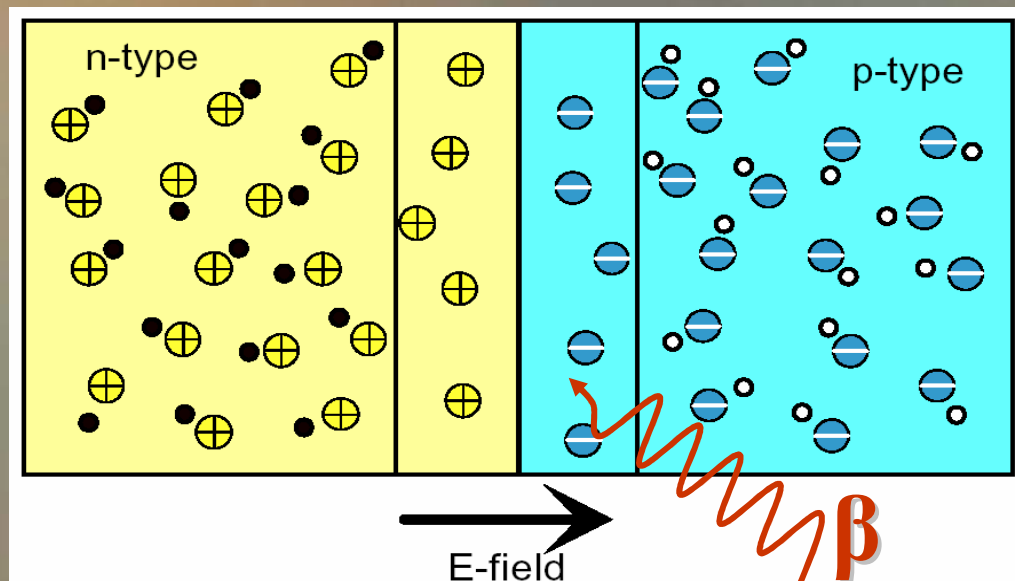

Betavoltaic

Just as photons create electron-hole pairs in a p-n junction (i.e. a solar cell), beta particles also generate electron-hole pairs after entering a p-n junction device.

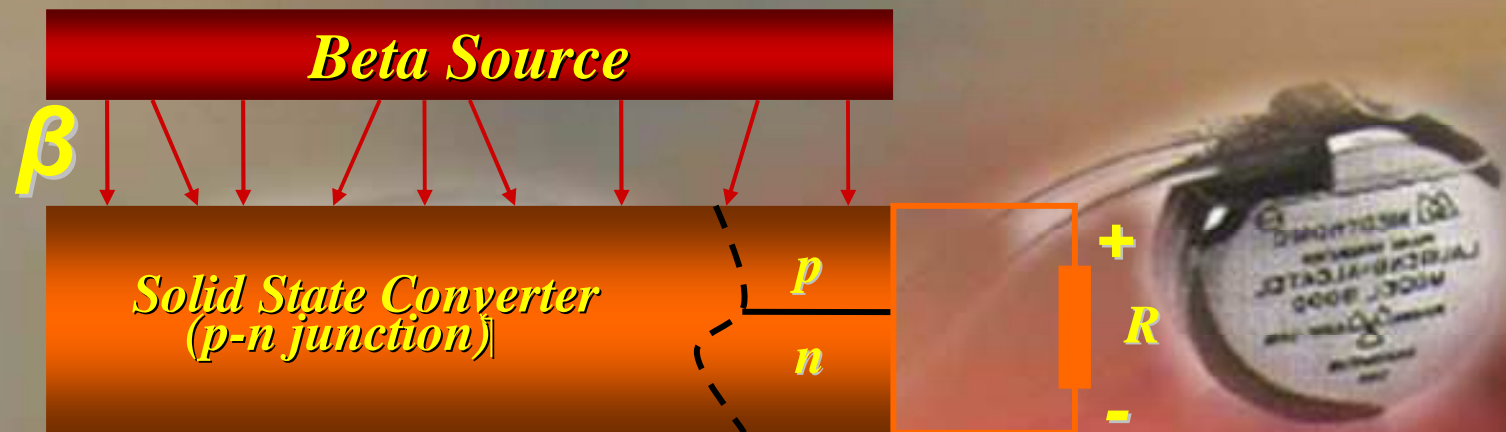

Betavoltaic

However, whereas a low energy photon creates just one electron-hole pair, a high-energy beta particle in p-n junction based devices can create a significant number of electron-hole pairs and a much greater current of low energy electrons.

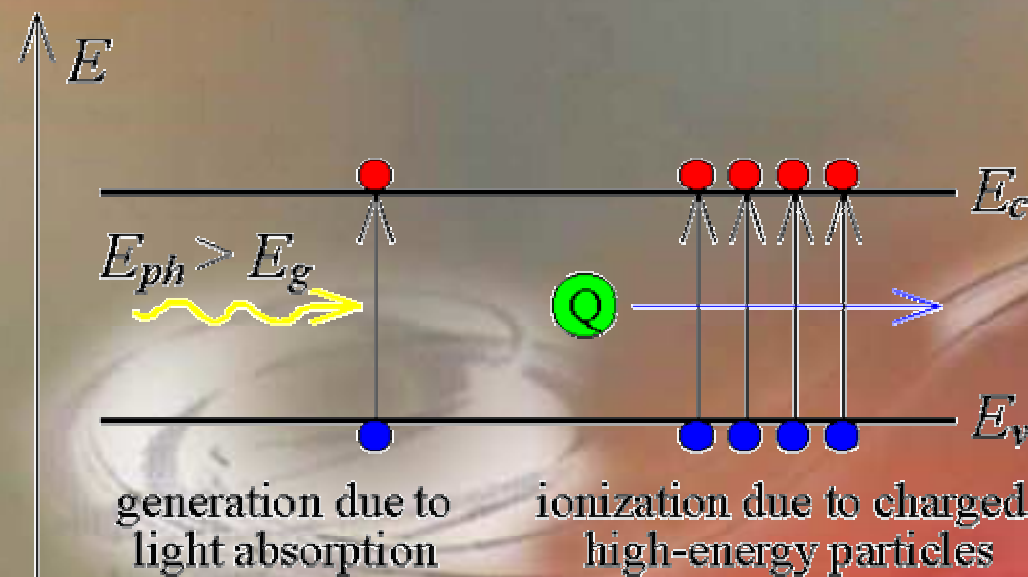

Betavoltaic Modeling

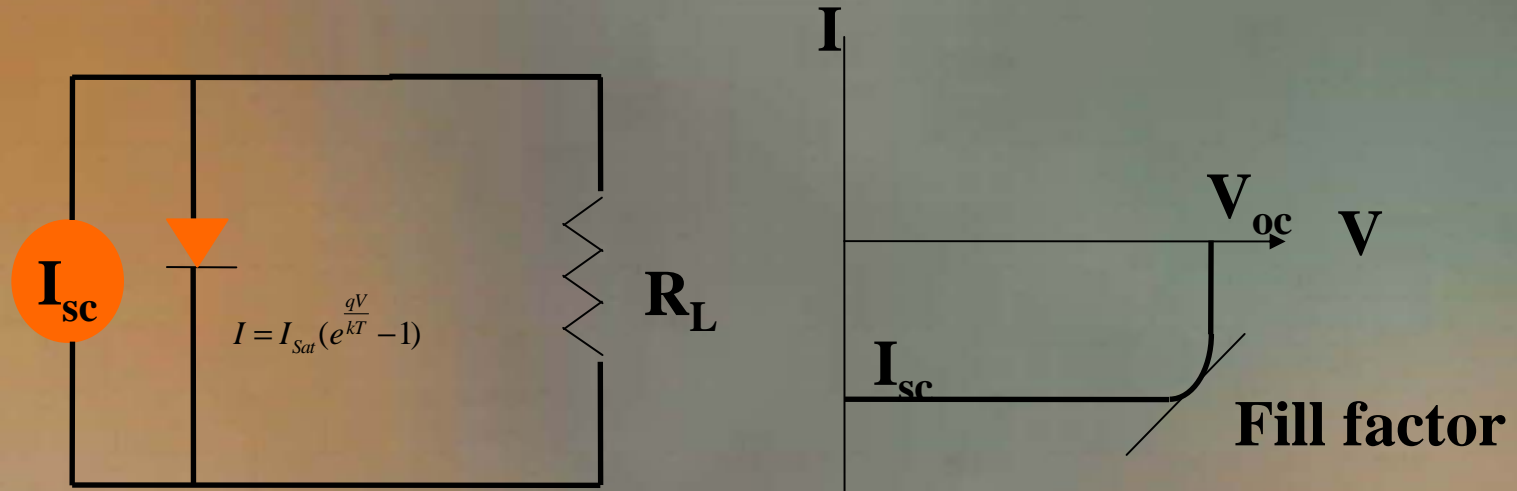

$$V_{oc} = \frac{nkT}{q} \ln(I_{sc}/I_0)$$

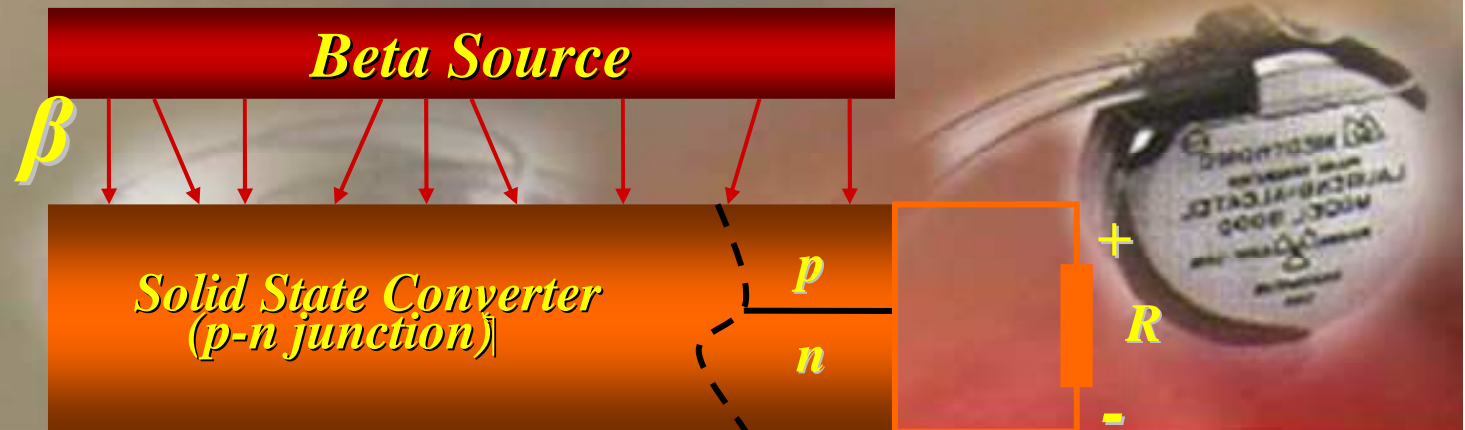



AMIRKABIR
University of Technology

Material and Methods



Isotope Selection

➤ Type of radiation

- Gamma
- Alpha
- Beta

➤ Half-Life

- Long \Rightarrow Long battery life
- Short \Rightarrow Higher power

➤ Energy of particles

- Depend on application
- Threshold energy of semiconductor Radiation Damage



Isotope Selection

- **Avoid gammas in the decay chain**
- **Toxicity of radioactive material**
- **Watch particle range**
- **Shielding Consideration**
- **Reliability**
- **Availability**
- **Manufacturing cost**



Isotope Selection

what already practically was used
is limited to

^{147}Pm , $^{90}\text{Sr}/\text{Y}$, ^{63}Ni , ^3H (Tritium)



Isotope Selection

Radioactive Source	Half-Life (year)	Specific Activity (GBq/g)	Maximum Decay Energy	Average Decay Energy	Specific Power μ Watt/Ci
Tritium, ^3H	12.3	357000	18.6 keV	5.7 keV	33.7
^{63}Ni	100	2190	67 keV	17 keV	100
^{147}Pm	2.6	36260	230 keV	73 keV	367
$^{90}\text{Sr}/\text{Y}$	28.6 41.52	5050	546 keV 2.283 MeV	196 keV 935 keV	

Isotope Selection

^{90}Sr one of the first radioactive elements used in a Betavoltaic device. It's good choice for higher power applications.

Tritium has a wide application in medicine, but its low half life limits its applicability.

^{147}Pm Half life is low and has also gamma radiation, However beta particle energy of it is higher than ^{63}Ni and tritium energy.

^{63}Ni pure beta emitting radioactive isotope that has a lower decay energy, higher half life, lower activity and power density, and It can be readily plated to the semiconductor surface



Isotope Selection

Radioactive Source	Half-Life (year)	Specific Activity (GBq/g)	Maximum Decay Energy	Average Decay Energy	Specific Power μ Watt/Ci
^{63}Ni	100	2190	67 keV	17 keV	100
^{147}Pm	2.6	36260	230 keV	73 keV	367
$^{90}\text{Sr}/\text{Y}$	28.6 41.52	5050	546 keV 2.283 MeV	196 keV 935 keV	

Semiconductor Selection

**Current *semiconductors* in this application:
Si, Ge, Ga and their compounds**

**Maximum bond energy/Minimal atomic
displacement probability
so *higher efficiency***

By using *Wide Band Gap* semiconductor

Such as;

silicon compounds; SiC, a-Si:H, ...

Nitride compounds; GaN, AlGaN, ...



Semiconductor Selection

Penetration depth is function of material density;

a denser material \Rightarrow shorter distances to absorb the incident radiation

**e.g. Si has approximately half the density of GaN
 \Rightarrow require twice the thickness to absorb the incident radiation**





AMIRKABIR
University of Technology

Semiconductor Selection

Attend to ;

- Wide Band Gap material
- High Density so as to better Penetration of radiation

Options;

SiC

GaN, ...



Why GaN ?

Property	Si	SiC	GaAs	GaN
Band gap (eV)	1.1	3.2	1.42	3.4
Breakdown field for 10^{17}cm^{-3} (MV/cm)	0.6	3	0.65	3.5
Saturated Electron Drift (cm/s)	10^7	2×10^7	1×10^7	2×10^7
Absorption depth of electron (μm)	3	~ 3	1.31	1.136
Density (g/cm^3)	2.33	3.2	5.3	6.15
radiation damage (keV)	145	-	225	~ 100
Heat Capacity (J/mol.K)	19.789	~ 1.2	47.02	34.9

Why GaN ?

**High Band Gap
High electric breakdown field
High saturated electron velocity
Resistance**

**Suited for harsh environment
high temperature
high resistant in radiation and defect**





AMIRKABIR
University of Technology

Semiconductor Selection

GaN;

- ✓ Wide band Gap crystal
- ✓ Very Hard
- ✓ Mechanically stable material
- ✓ Large Heat Capacity
- ✓ High resistant to the creation of defects and radiation damage
⇒ Stable Voltage





AMIRKABIR
University of Technology

Simulation





Simulation & Calculation

Amount of electron-hole generation



Flux and Spatial Distribution of emitted β particles in semiconductor



Amount of Energy and Charge Deposition



Geometry

Device comprises;

Central Radioisotope as a layer of ^{63}Ni
surrounded by two p-n Junctions from GaN

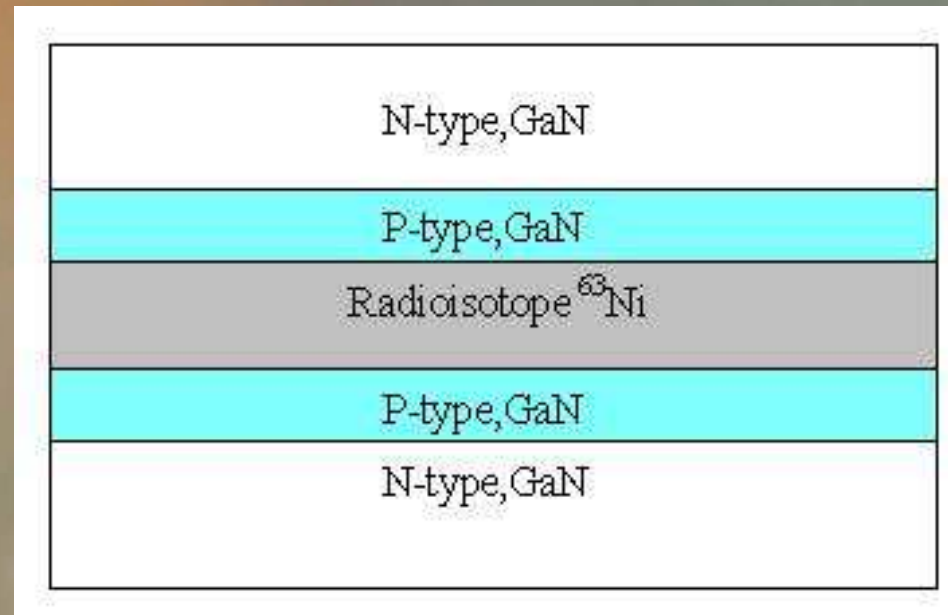

Structure of GaN Betavoltaic device



Source thickness

- **Lower radioisotope thickness limit;**
is determined by required power depending on application and production technology
- **Upper radioisotope thickness limit;**
by Self-absorption of emitted particles (commonly between 0.1 to 5 μm)



Source thickness

Saturation Thickness;

Practically, because the very short ranges beta particles emitted from ^{63}Ni , there exists a saturation thickness for source and GaN layers.

Thicknesses that are greater than these saturation values will not produce additional electrical power.

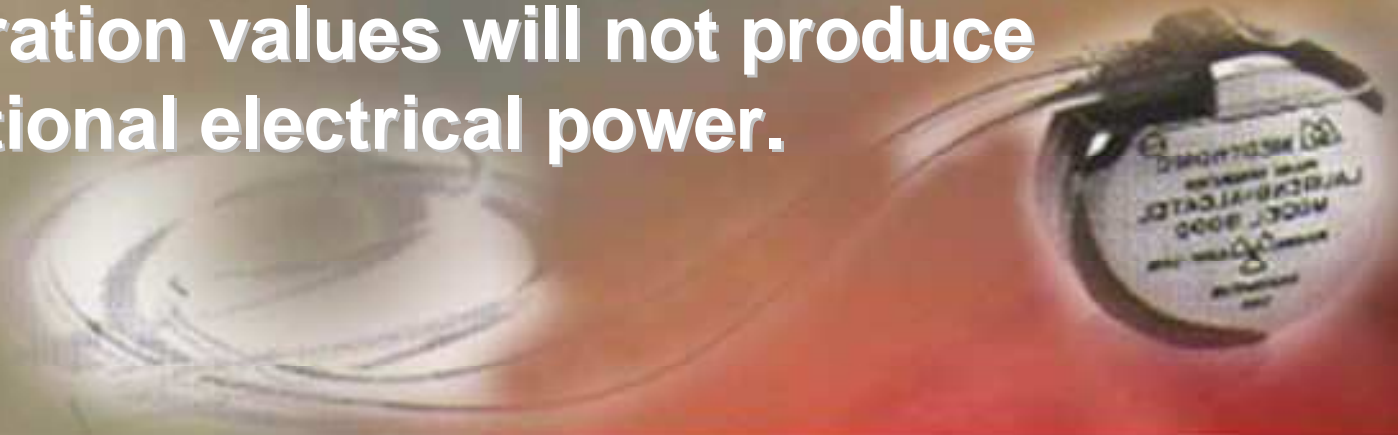

Optimal thickness of Semiconductor

- If junction is too deep, most particles will Stop
- If too shallow, performance will be poor

⇒ it needs to determine the optimum thickness



Optimum thickness

Power Available to a GaN radioisotope converter as a function of the ^{63}Ni layer and GaN layers thickness of our configuration,

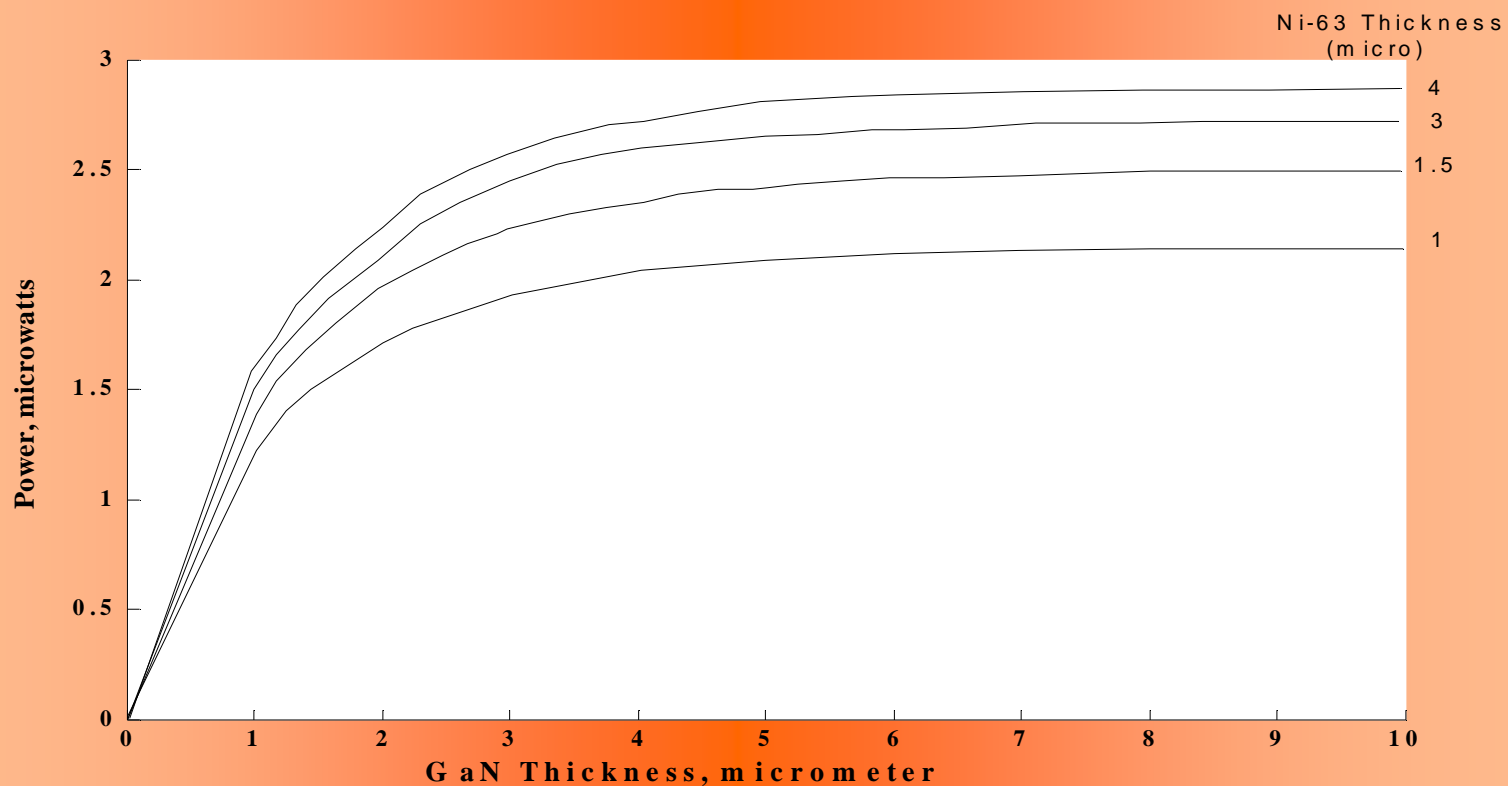

Optimum thickness

According to the graph and economic consideration, optimum thicknesses are determined, that is

GaN;

P-type region 1 μm

N-type region 3 μm

^{63}Ni 1.5 μm

It's only for one cell. According to application it can be used several cells.



Recombination and Charge Collection

**Net current obtain according to
generation-recombination
and
charge collection probability
in all regions**





AMIRKABIR
University of Technology

Results



Results

Simulation results of GaN Betavoltaic with ^{63}Ni

Betavoltaic Battery	Optimum thickness μm	Jsc $\mu\text{A}/\text{cm}^2$	Voc (Volt)	Energy Content mW-hr/mg	Life Time (Year)	Efficiency η
GaN P-type region N-type region ^{63}Ni	1 3 1.5	1.1	2.7	204.55 (4 years)	>30	25%
Lithium/Iodine	1 mg	6.1	2.5	0.5	5-10	
Lithium-Ion	1 mg	3.79	2.5	0.3	5-10	

Volume Relation is $\sim 7.5/0.025 \sim 300$

Results

Betavoltaic Battery	Optimum thickness μm	Jsc $\mu\text{A}/\text{cm}^2$	Voc (Volt)	Efficiency η
AlGaN ^{63}Ni	Same configuration	0.71	5.07	26.98%
SiC ^{63}Ni	Same configuration	0.806	2.67	-



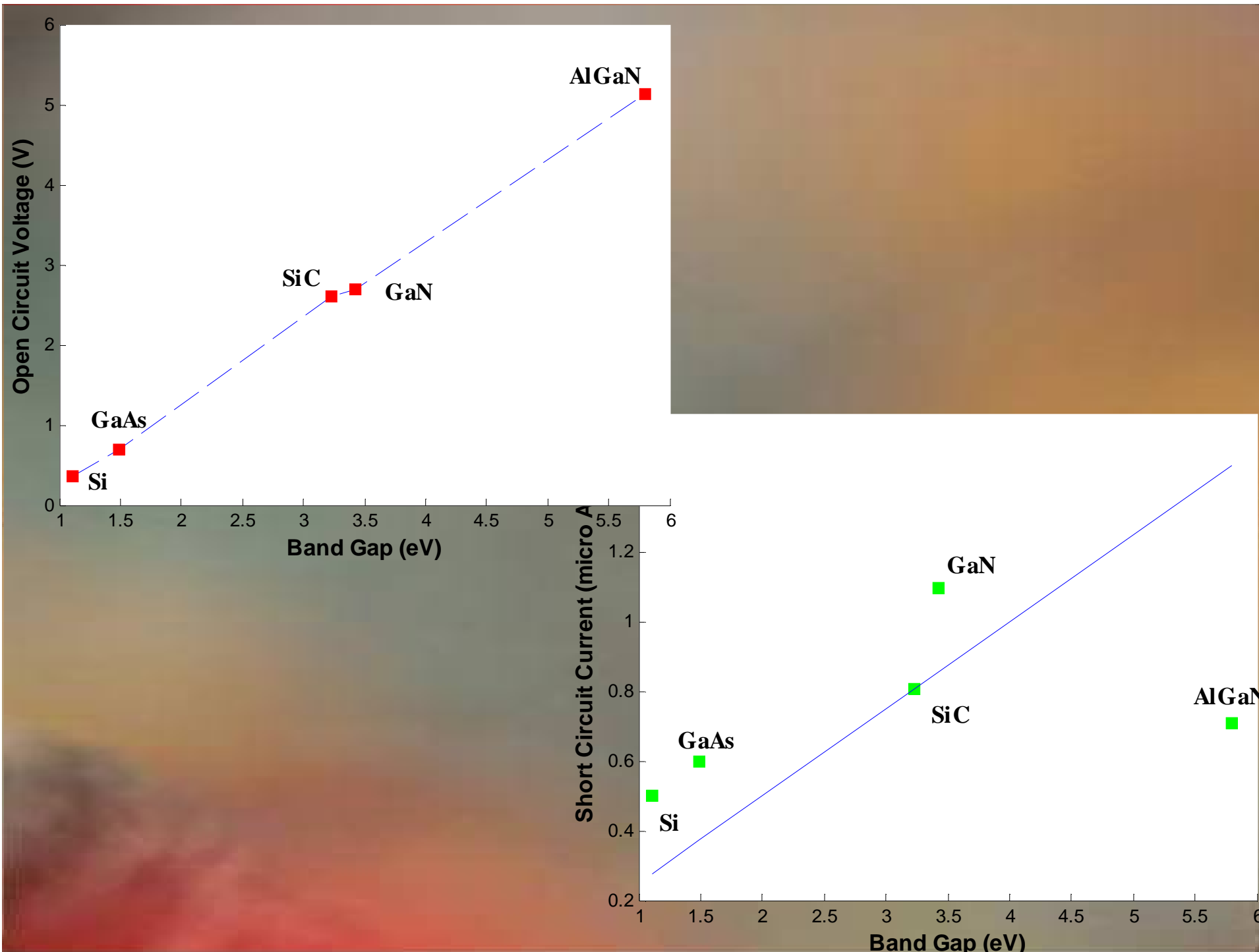

Conclusion

Worldwide, more than 250,000 permanent cardiac pacemakers are implanted each year. Pacemakers are becoming more common everyday and the number of implants continues to increase.

Generally, Betavoltaic batteries can be useful in many low-power equipments, especially due to higher efficiency and more safety because of very short ranges beta particles emitted from using radioisotope which require minimal shielding and are unable to penetrate human skin.

Also, they will be suitable replacement for thermoelectric devices which have lower efficiency .



Conclusion

In comparison with chemical batteries;

- Long life
- High energy density

In comparison with other nuclear batteries;

- more safety because of very short ranges beta particles emitted from using radioisotope
- outstanding for light and small scale systems like MEMs
- High Efficiency

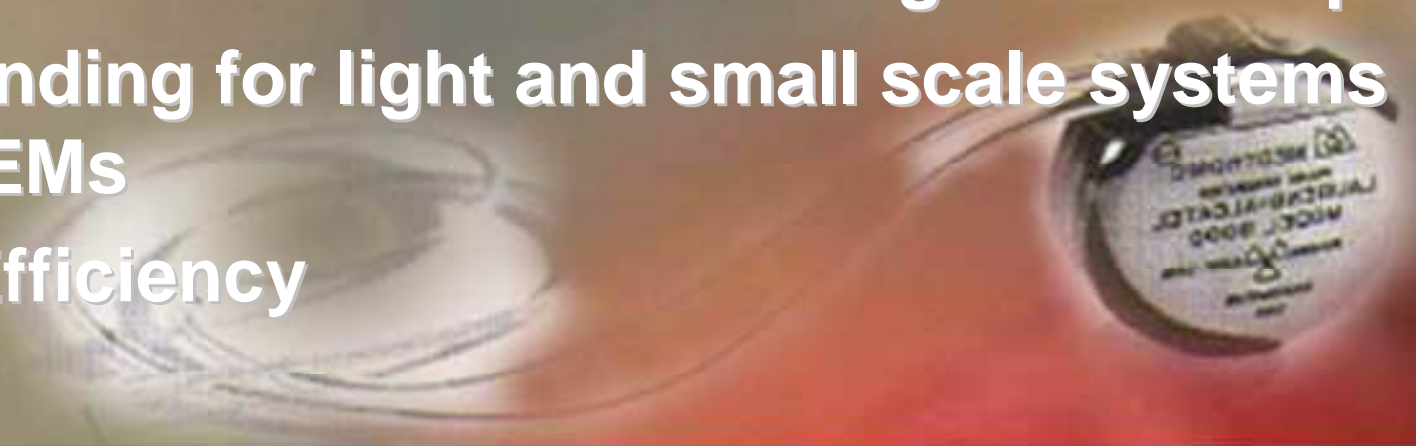

Future Works

- Other Configuration for increasing the efficiency
- Mixed the material and have a heterojunction device
- Special arrangement of layers
- Using other material such as SiC, AlGaIn, ...



