

Innovative 3-D Neutronics Analyses Directly Coupled with CAD Models of Geometrically Complex Fusion Systems

Mohamed Sawan

P. Wilson, T. Tautges(ANL), L. El-Guebaly, D. Henderson,
T. Bohm, G. Sviatoslavsky,
B. Kiedrowski, A. Ibrahim, B. Smith, R. Slaybaugh

13th International Conference on
Emerging Nuclear Energy Systems

ICENES2007

Istanbul, Turkey

June 3-8, 2007



THE UNIVERSITY
of
WISCONSIN
MADISON

Fusion Reactors are Complex with Many Components

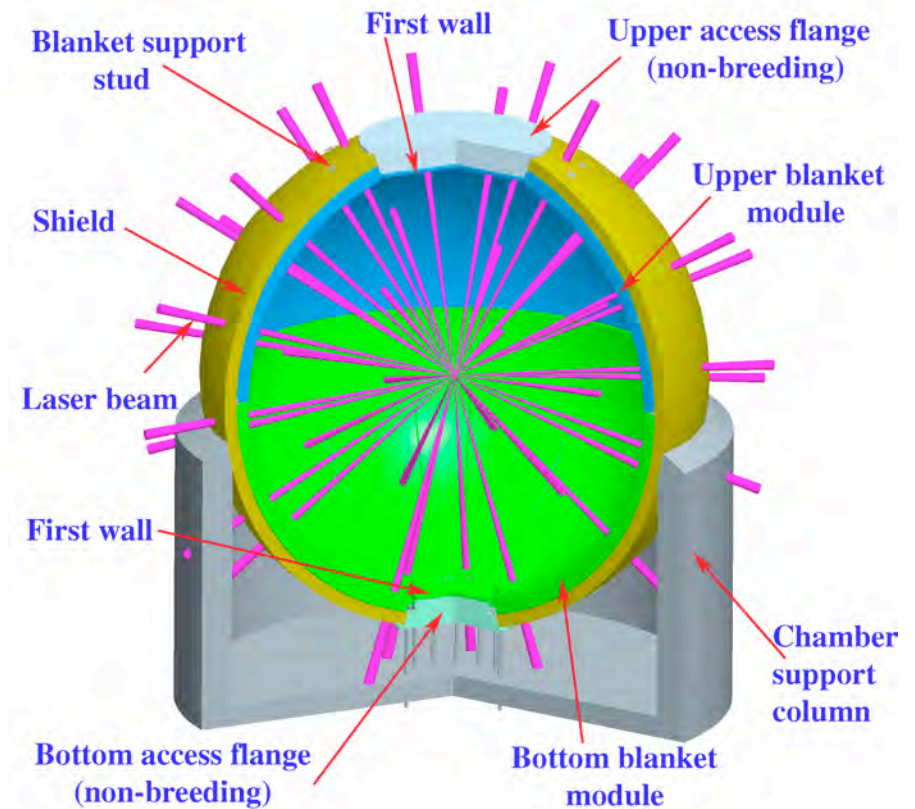
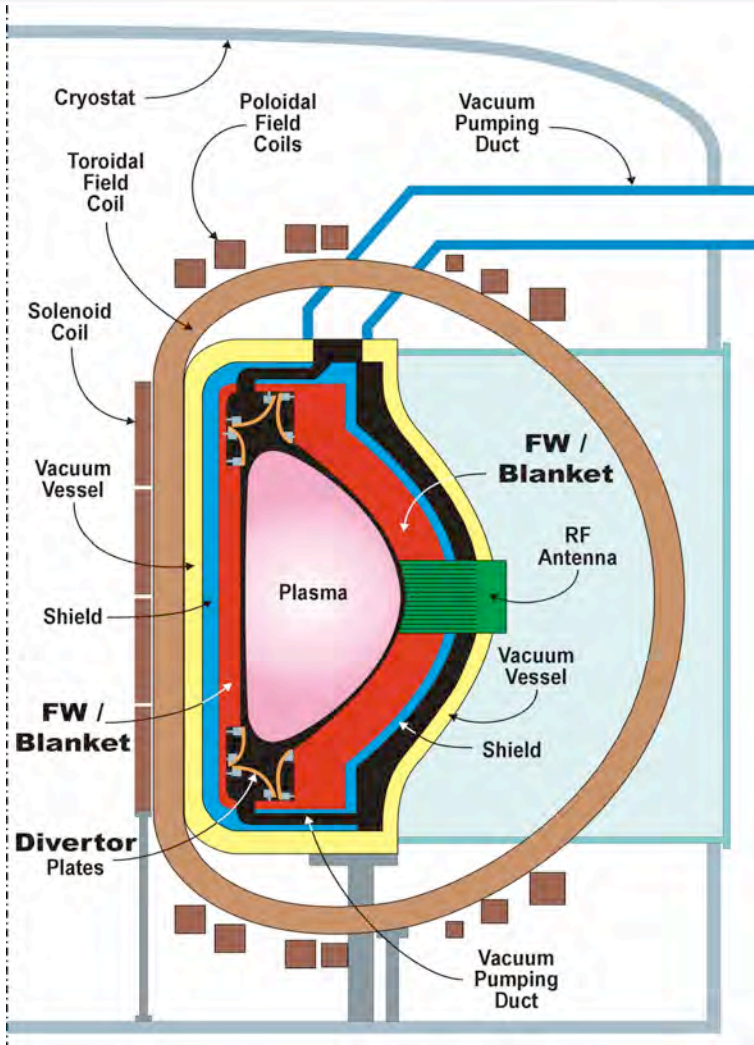

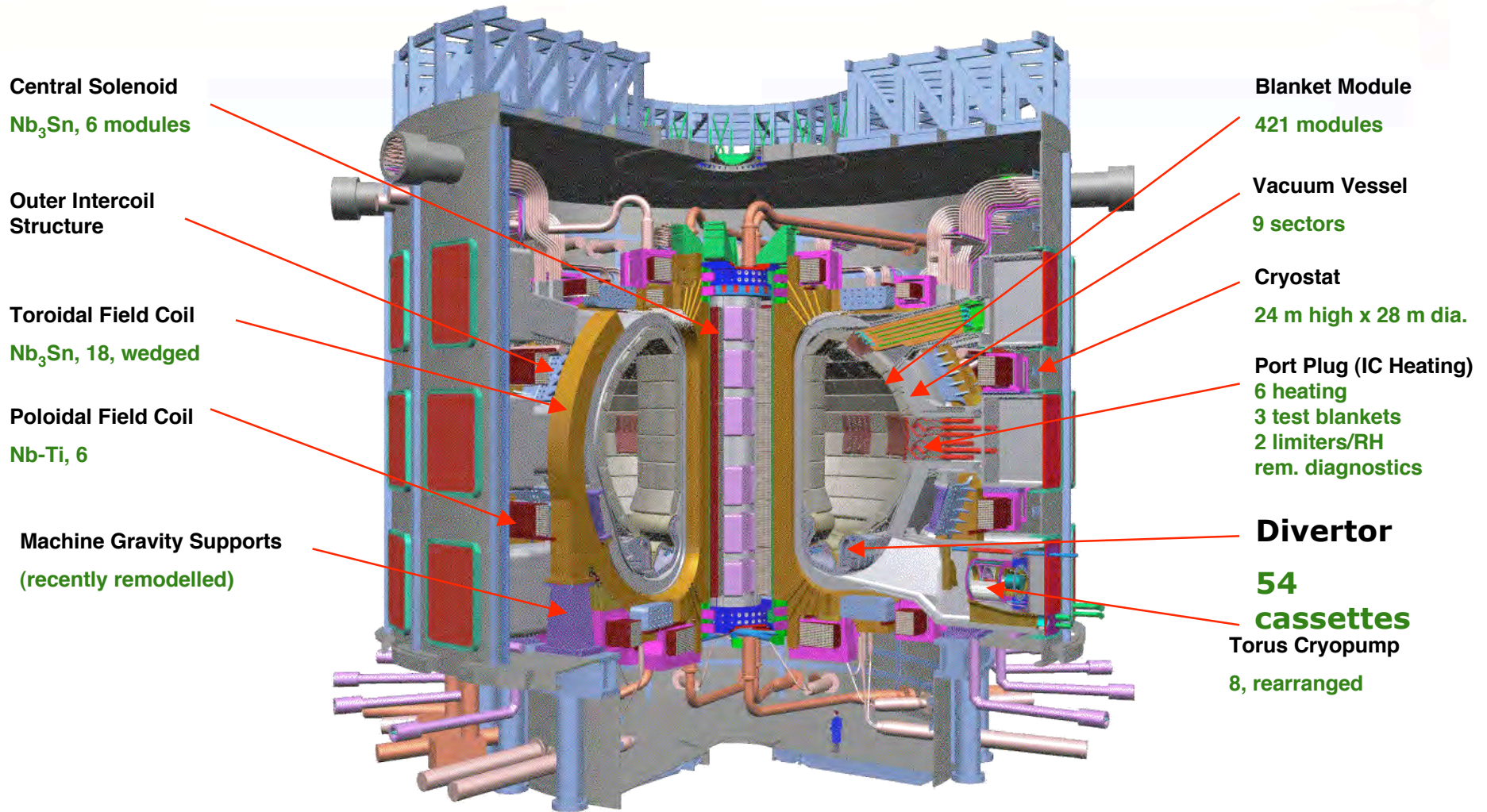

ITER Status

- Agreement signed on November 21, 2006
- Seven parties with more than half of the world population
- Cost ~\$7B
- ITER construction starts in 2007 at Cadarache, France
- First plasma in 2016 and 20 year operation

ITER diagnostics landscape

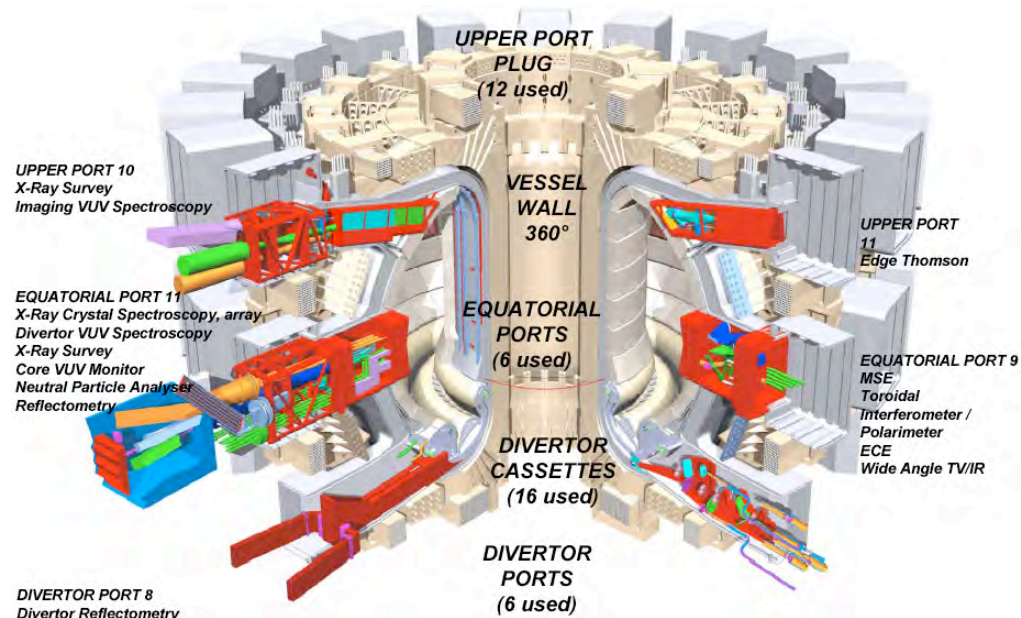



Nuclear Analysis is Essential Part of Fusion Reactor Design

- Tritium production in breeding blankets to ensure tritium self-sufficiency
- Nuclear heating (energy deposition) for thermal analysis and cooling requirement
- Radiation damage in structural material and other sensitive components for lifetime assessment
- Provide adequate shielding for components (e.g., magnets) and personnel access
- Activation analysis for safety assessment and radwaste management

- Direct use of solid model geometry in MCNP
 - Use Common Geometry Module (CGM) to interface MCNP *directly* to CAD & other geometry data

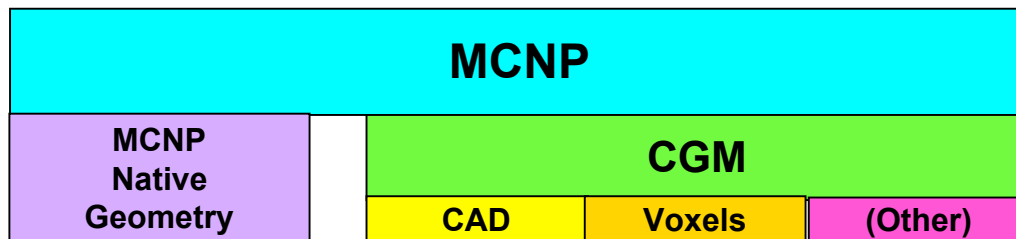

Ray-tracing acceleration techniques used allowing for tracking speeds that are within a factor of 2-3 of the native MCNP

- Production experience
 - ITER Benchmark
 - ARIES-CS
 - HAPL
 - ITER FWS

Motivations

- Reduce impacts of manual conversion of 3-D model data
 - Reduce preparation time and allow faster design iterations
 - Avoid need for geometrical simplifications to 2nd order polynomials
 - Eliminate possible human errors in modeling
- Extend richness of geometric representation by preserving geometrical details

CAD Issues Requiring “Repair”

Human effort shifts from traditional MCNP model creation to CAD/Solid Model repair

- Overlapping Volumes (i.e.: clashes)
- Mating surfaces not contacting
- Slight “Misalignment”

Examples of Typical CAD Issues and Typical Repairs

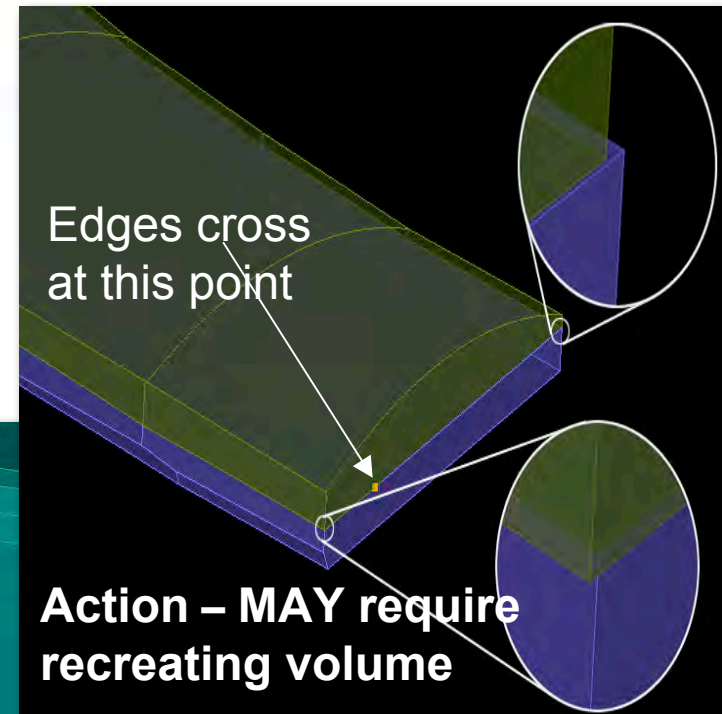
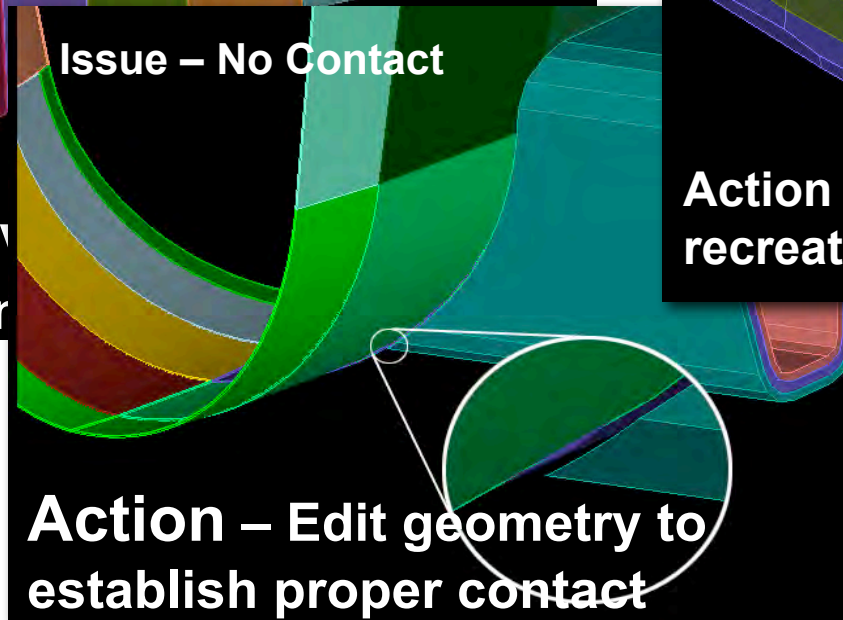
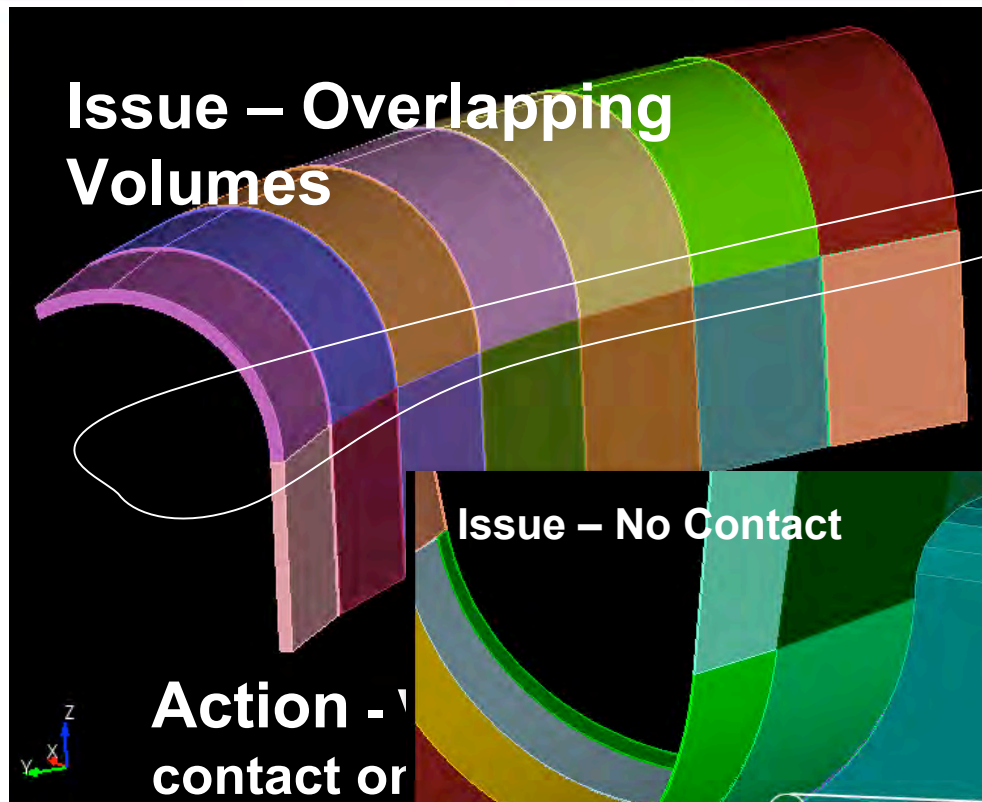

ITER Benchmark

- 40 degree machine sector
- Used for validation of MCNP/CAD tool
- 802 cells
- 9834 surfaces
- 17 material specifications

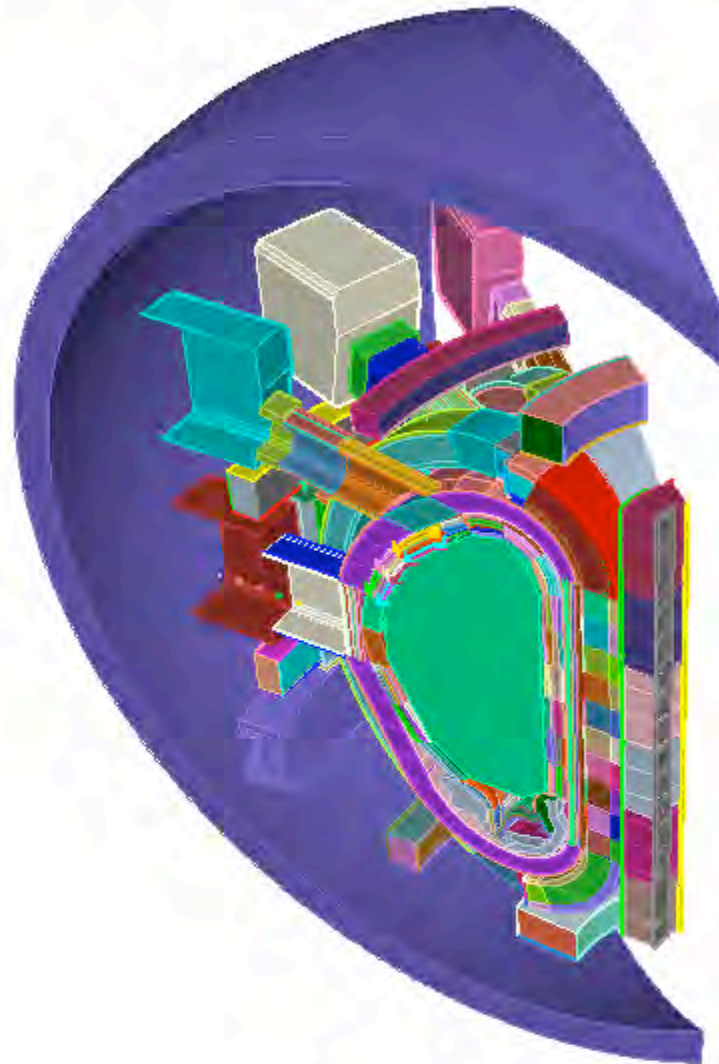

ITER Benchmark

- Comparing 4 results
 - Neutron wall loading
 - Divertor fluxes and heating
 - Magnet heating
 - Midplane port shielding/streaming
- Participants
 - UW, FZK, ASIPP, JAEA, UCLA

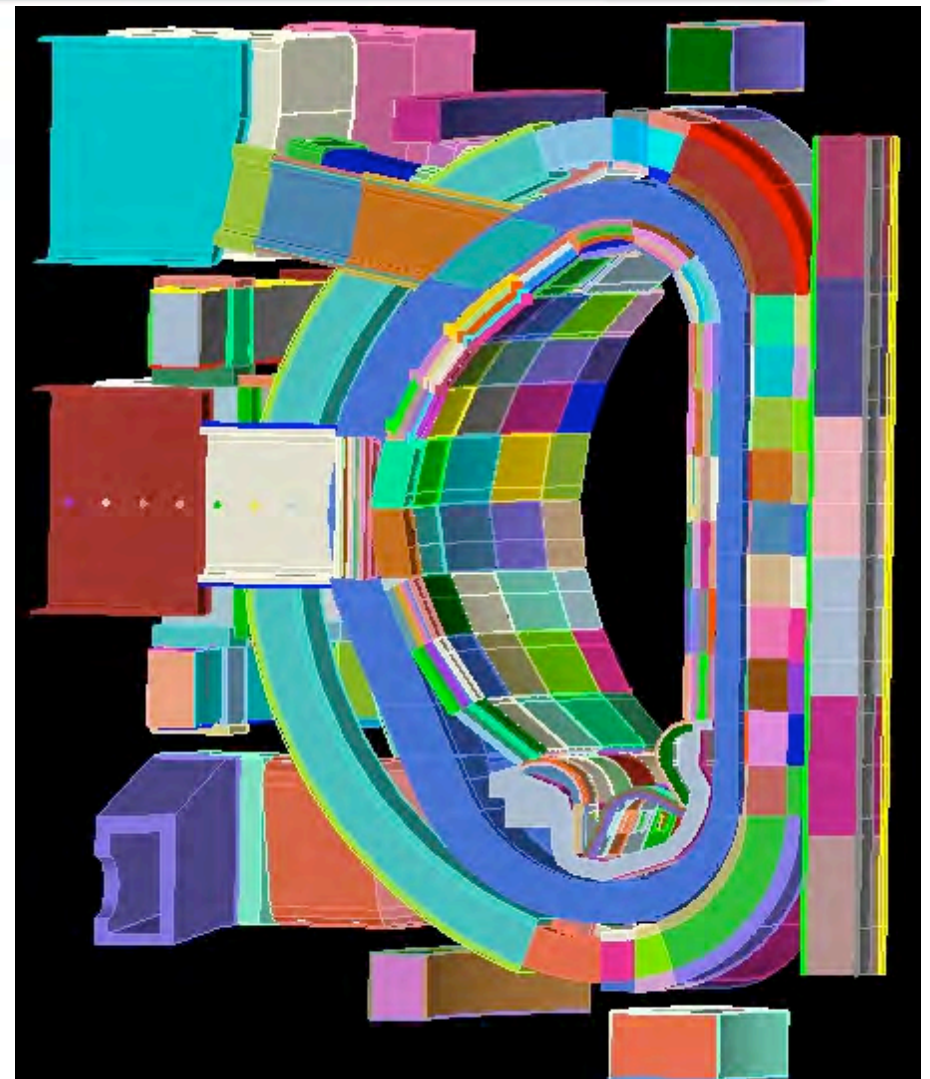

Neutron Wall Loading : results

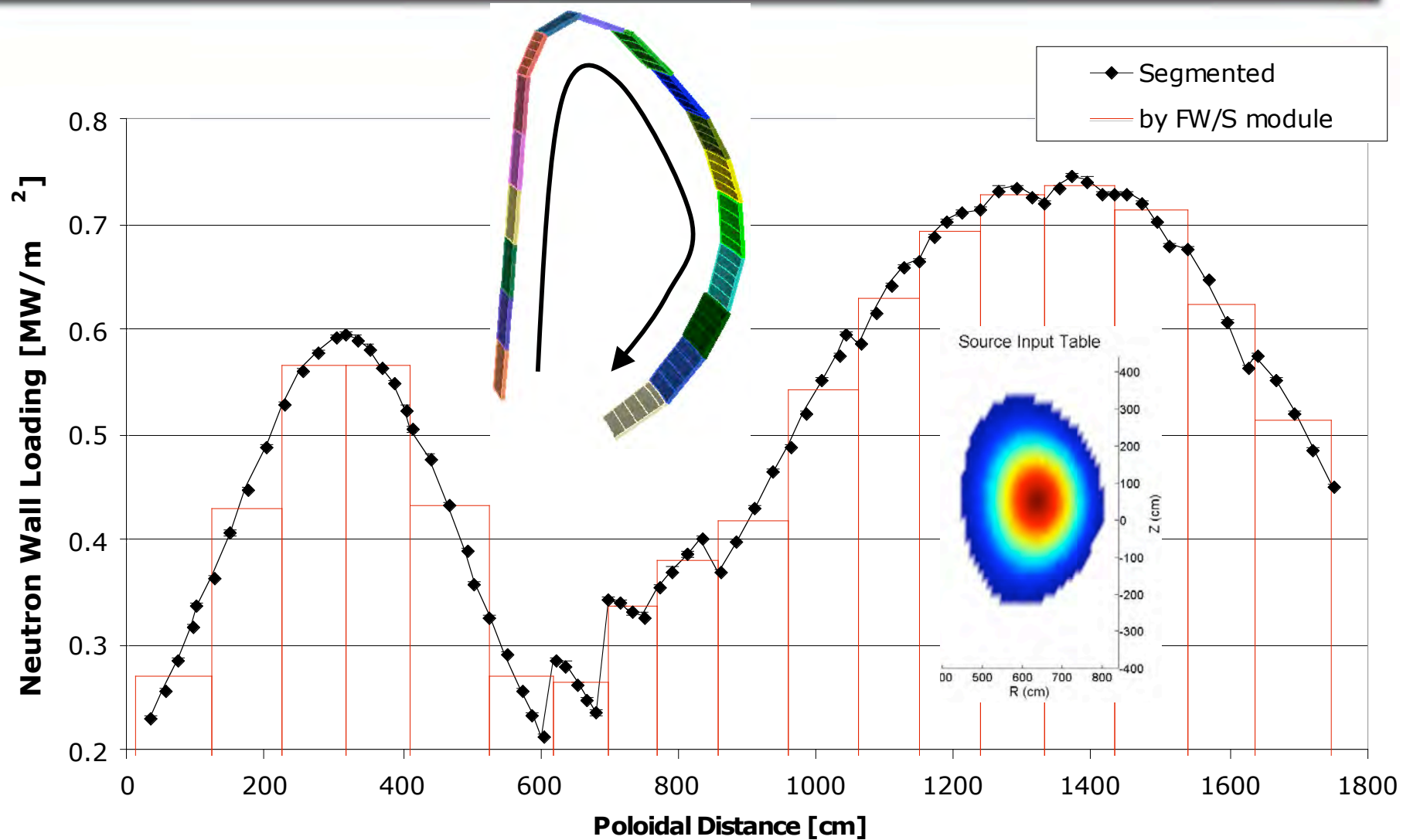

TF Coils : results

Nuclear Heating per Coil (W)

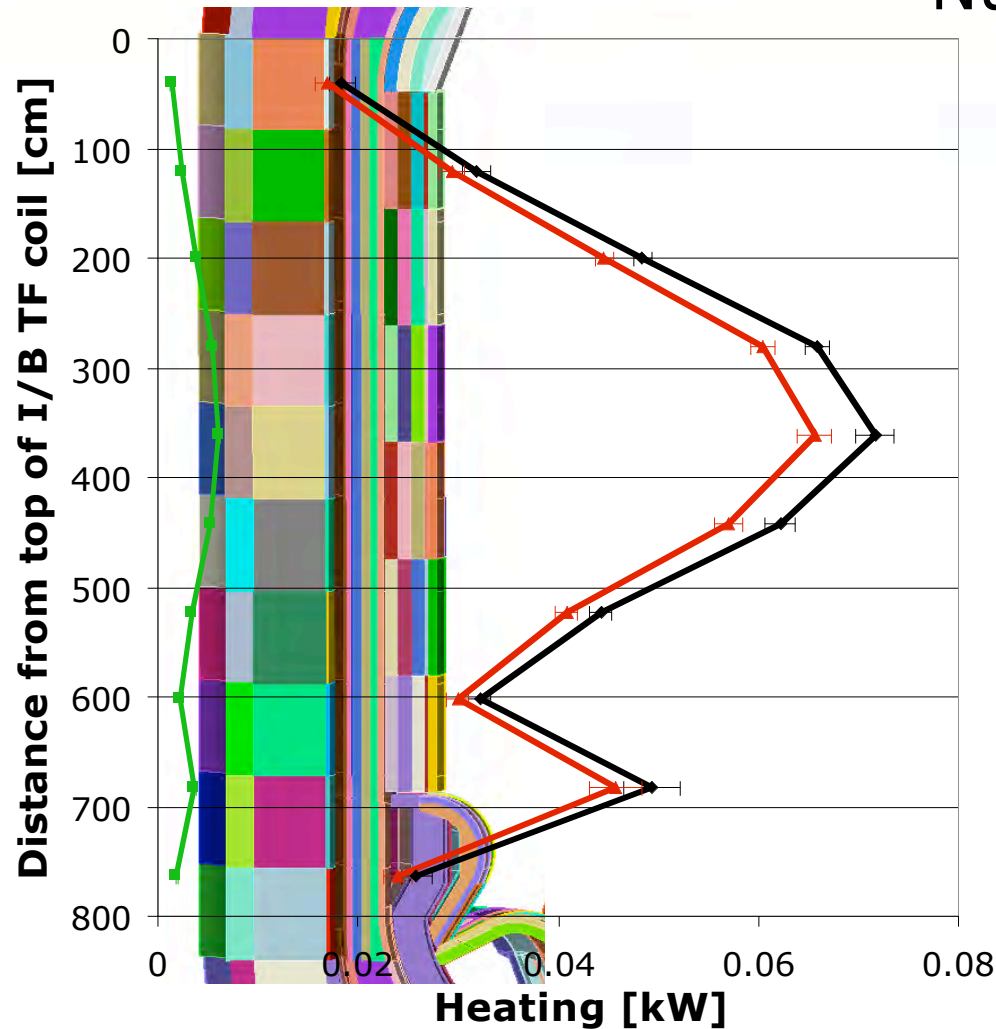

Neutron	Photon	Total
1.39 ± 0.05	17.0 ± 0.6	18.4 ± 0.6
2.47 ± 0.06	29.4 ± 0.6	31.8 ± 0.7
3.82 ± 0.04	44.6 ± 0.4	48.4 ± 0.5
5.41 ± 0.05	60.4 ± 0.6	65.8 ± 0.6
6.03 ± 0.12	65.6 ± 0.9	71.6 ± 1.0
5.16 ± 0.08	57.0 ± 0.7	62.2 ± 0.8
3.38 ± 0.04	40.9 ± 0.5	44.3 ± 0.6
2.27 ± 0.04	29.9 ± 0.5	32.2 ± 0.6
3.66 ± 0.08	45.7 ± 1.3	49.4 ± 1.4
1.88 ± 0.05	24.0 ± 0.7	25.9 ± 0.7
35.5 ± 0.2	415 ± 2.3	450 ± 2.5

8.1 kW in all TF I/B legs

Application to ARIES-CS Compact Stellarator

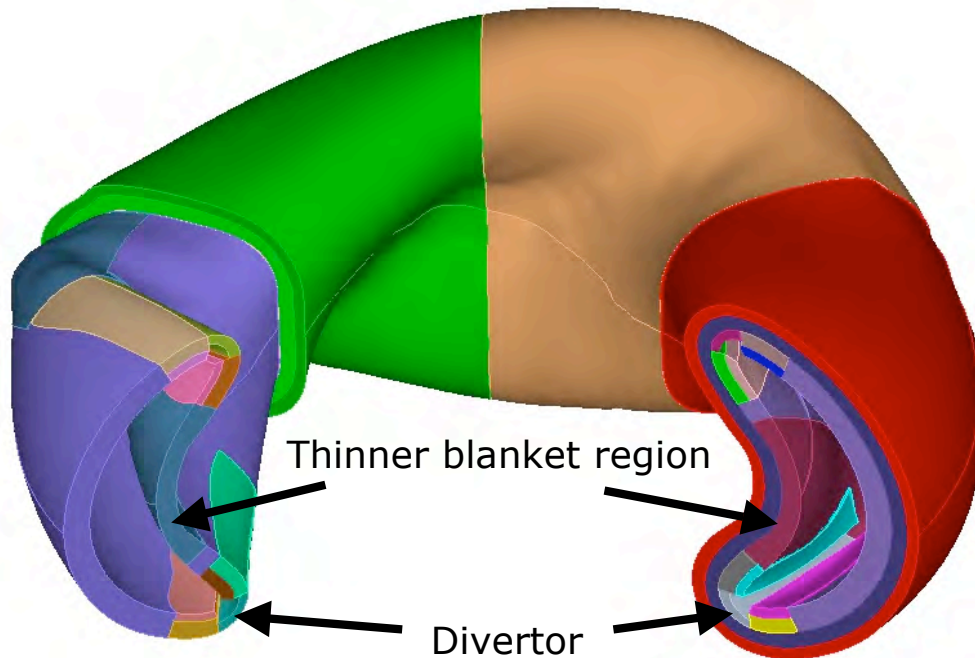

- Geometry complex
- FW shape and plasma profile vary toroidally within each field period
- Cannot be modeled by standard MCNP

Examined effect of helical geometry and non-uniform blanket and divertor on NWL distribution and total TBR and nuclear heating

NWL Maps (colormaps in MW/m²)

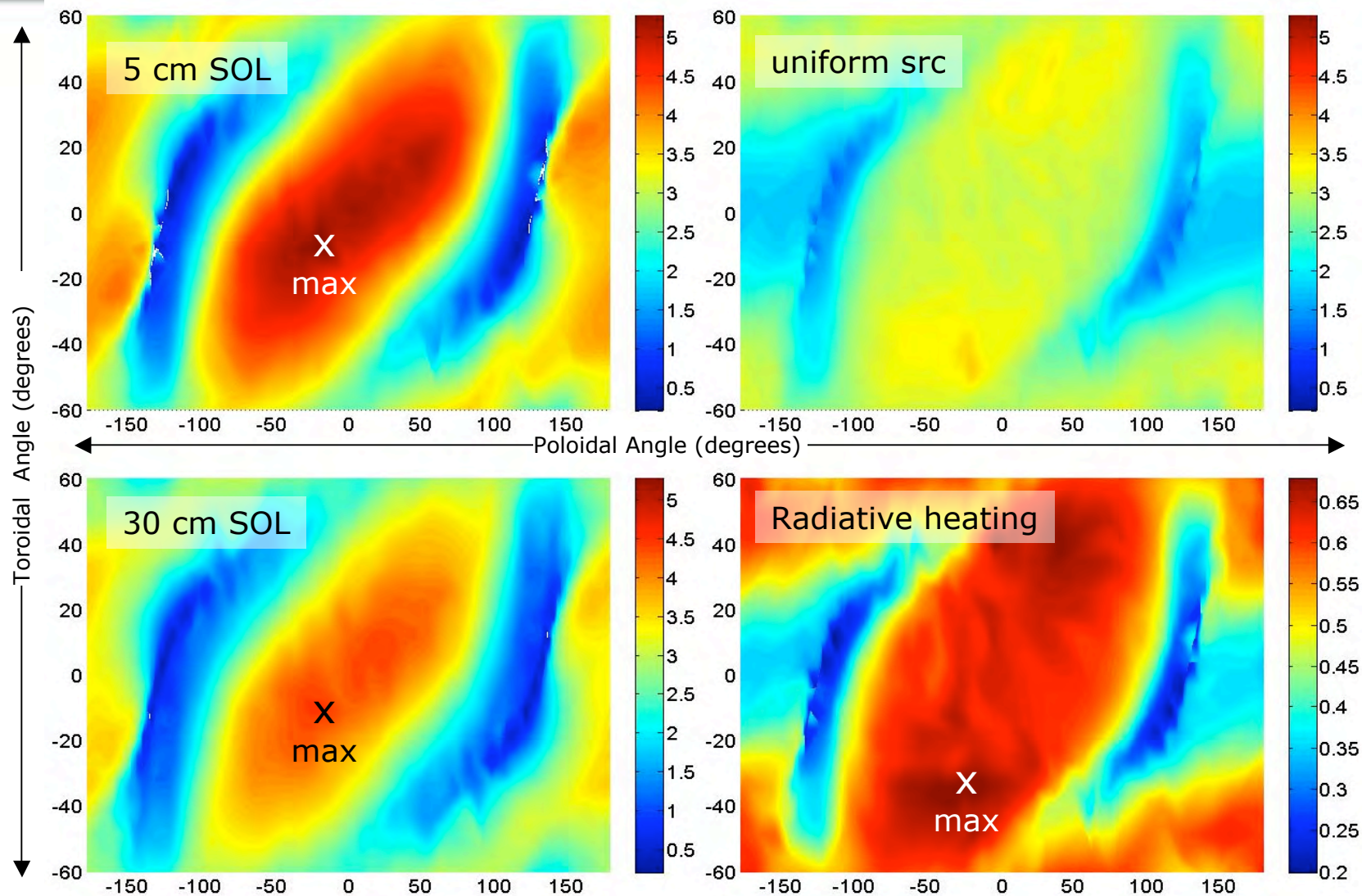

TBR: 3-D Results Differ from 1-D

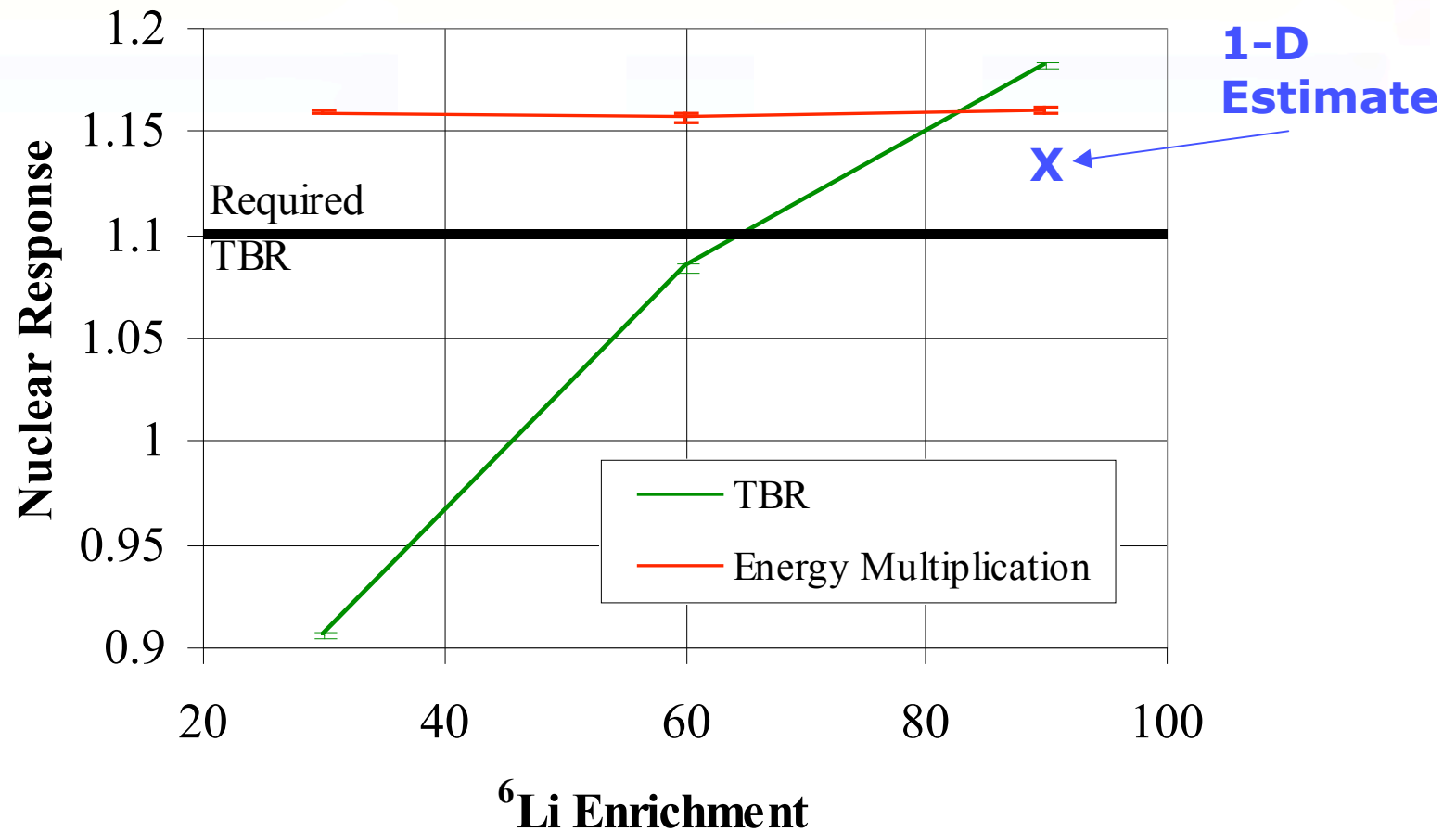

HAPL Final Laser Optics

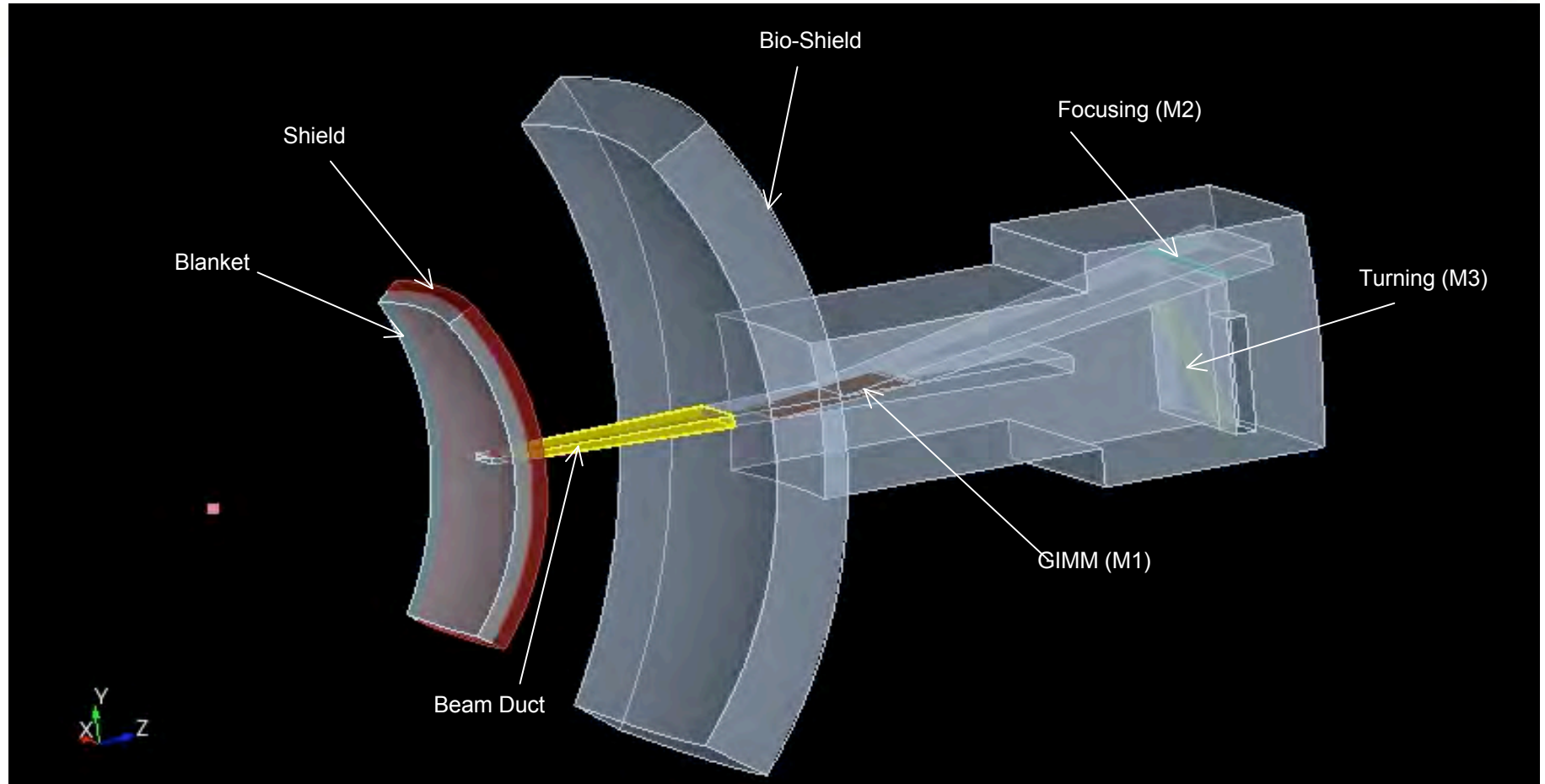

Neutron Flux in Laser Beam Duct

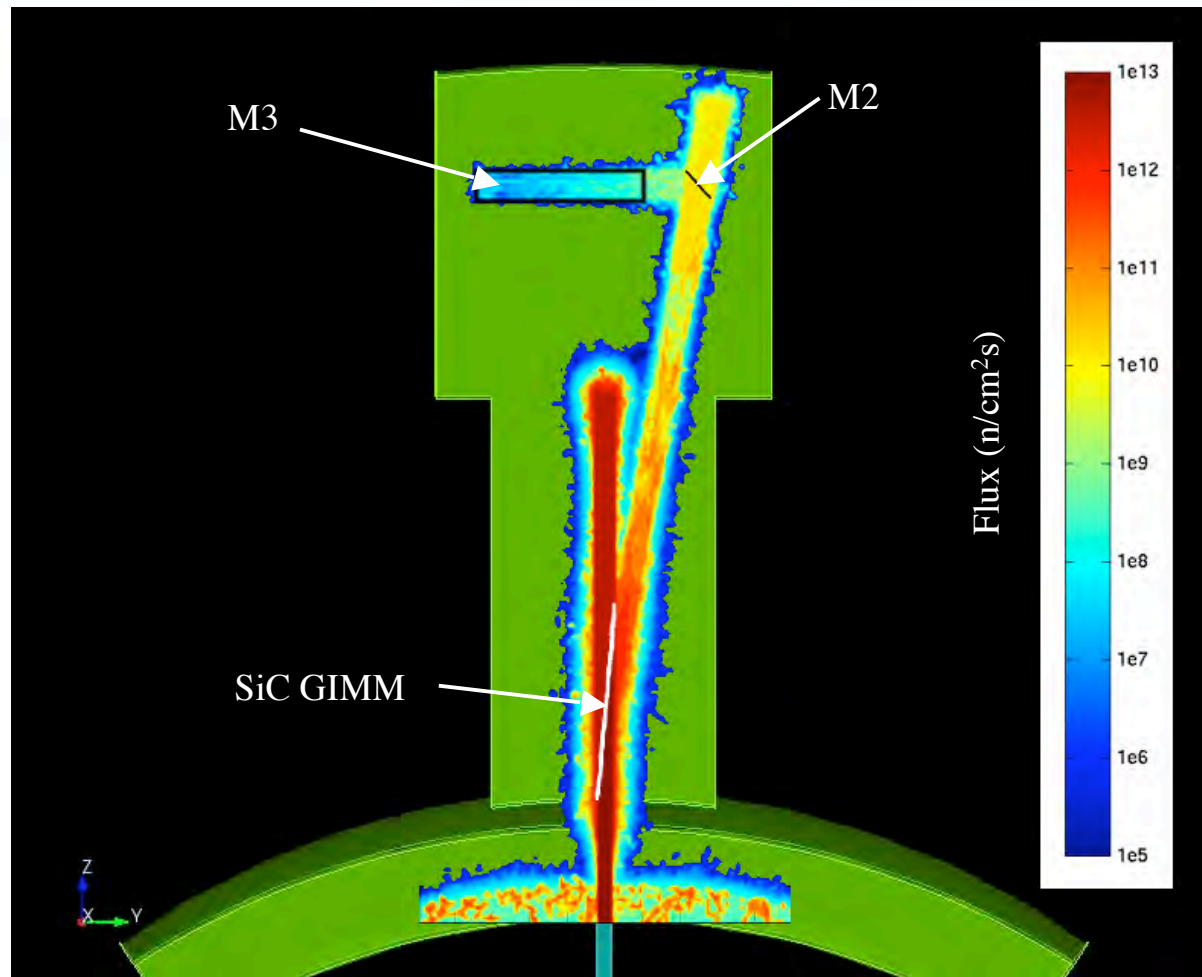

ITER FWS Module Elements

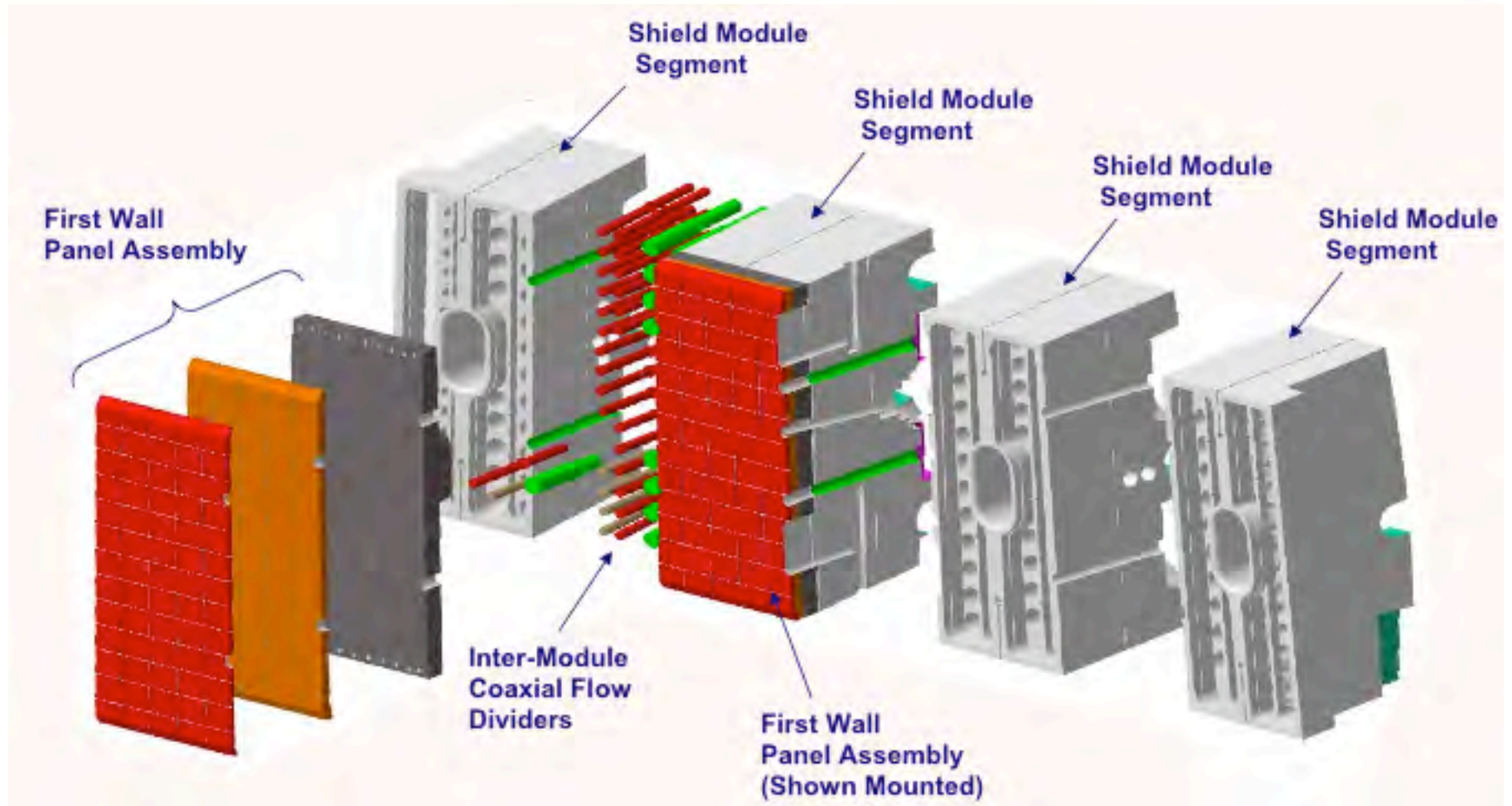

ITER First Wall/Shield Module 13 Mockup

Model generated by designers using
standard tools (CATIA/CUBIT)

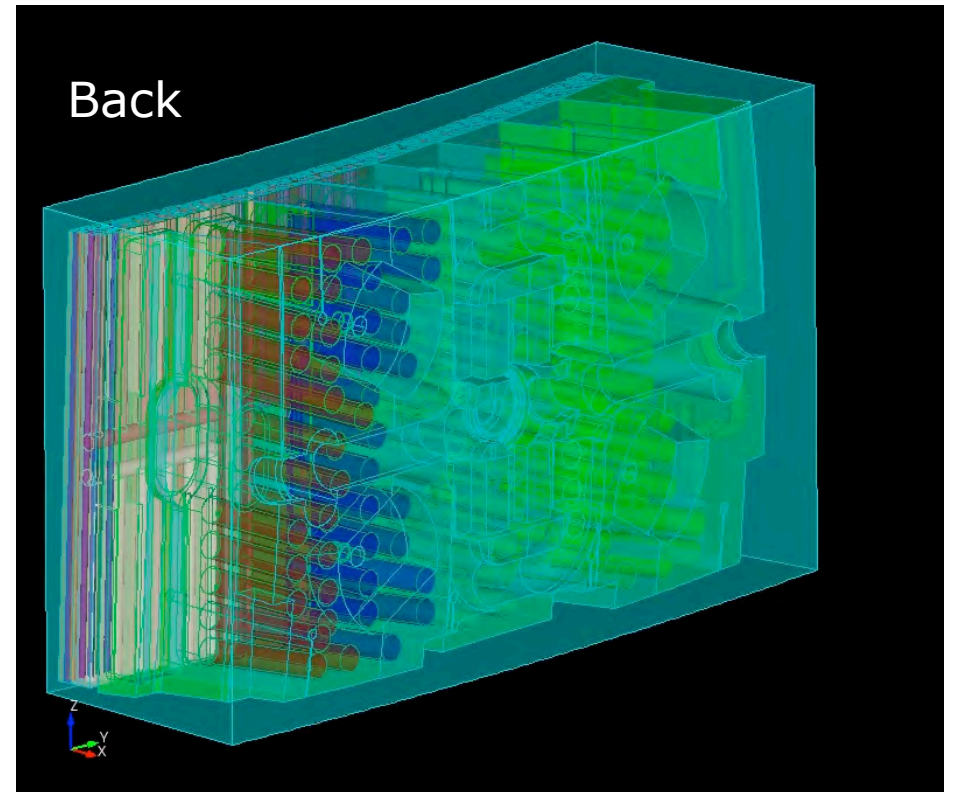
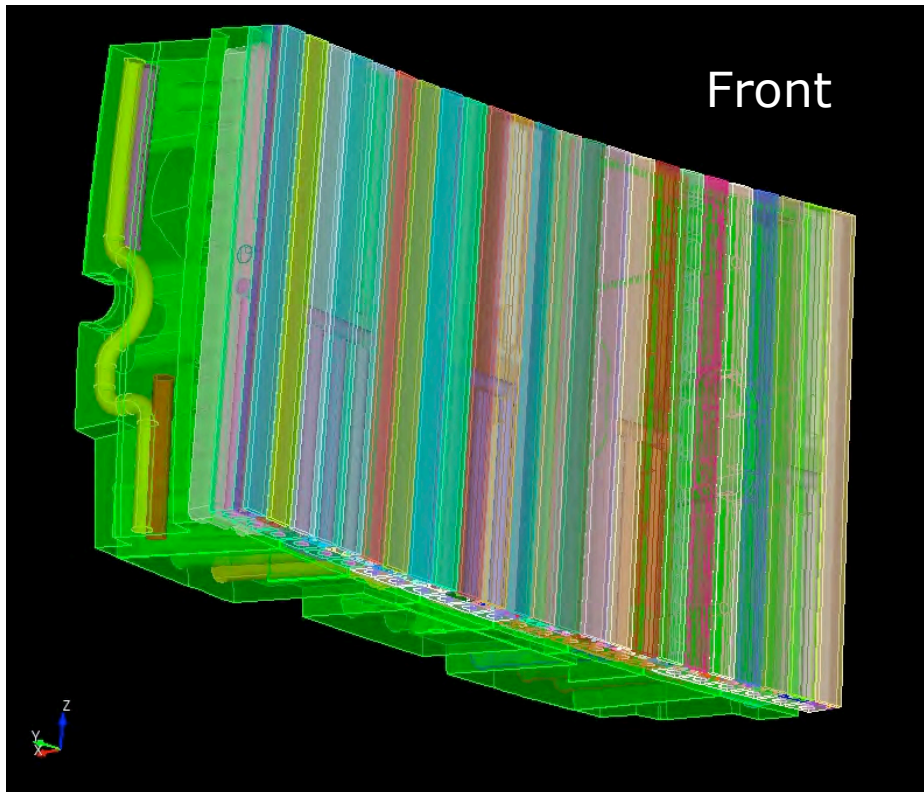

Nuclear responses at reservoir (11.5 cm from front of FW)

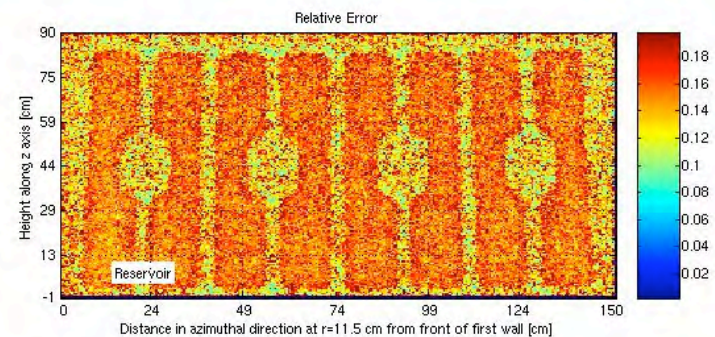
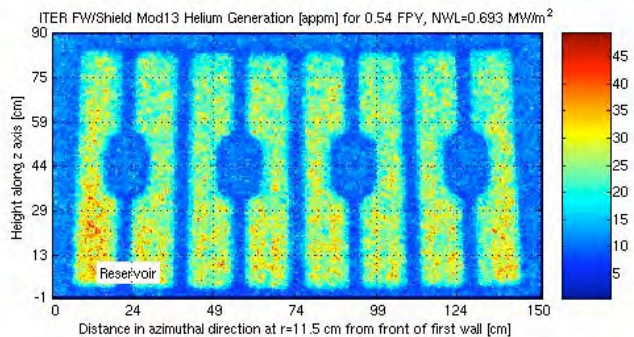
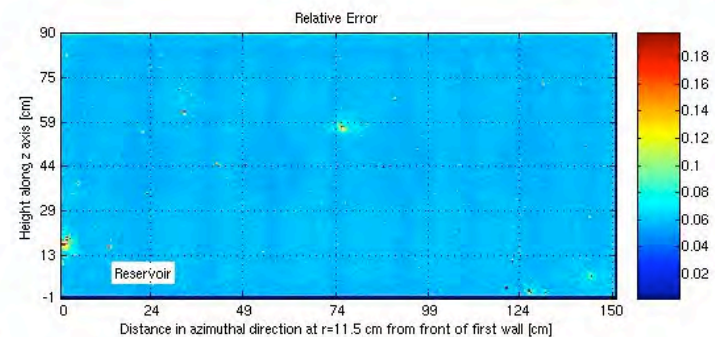
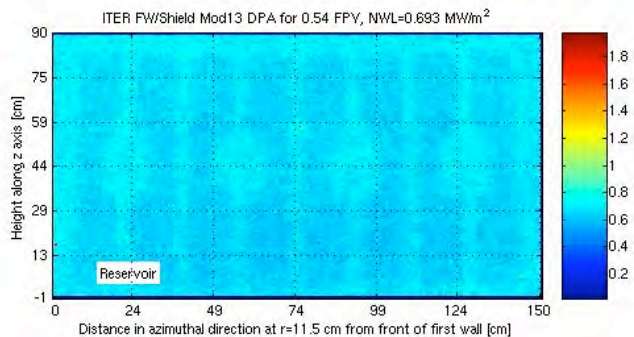
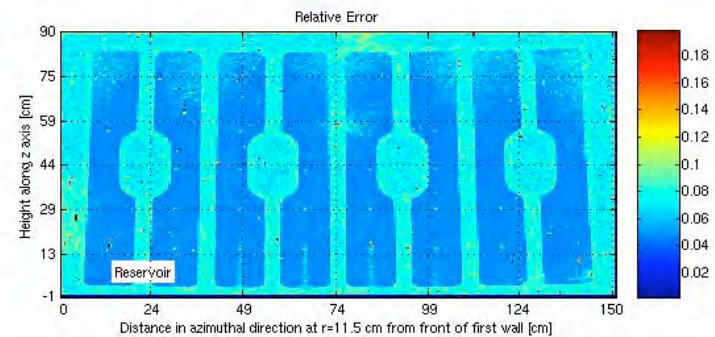
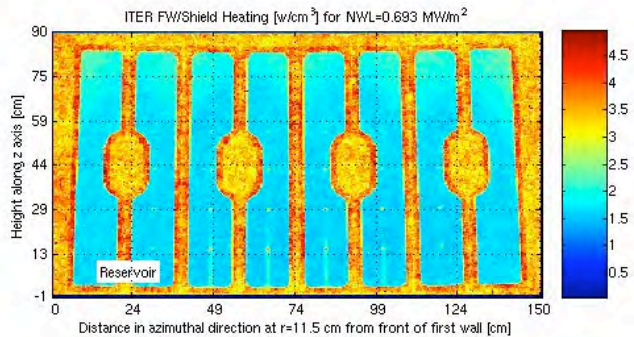

FWS nuclear heating results

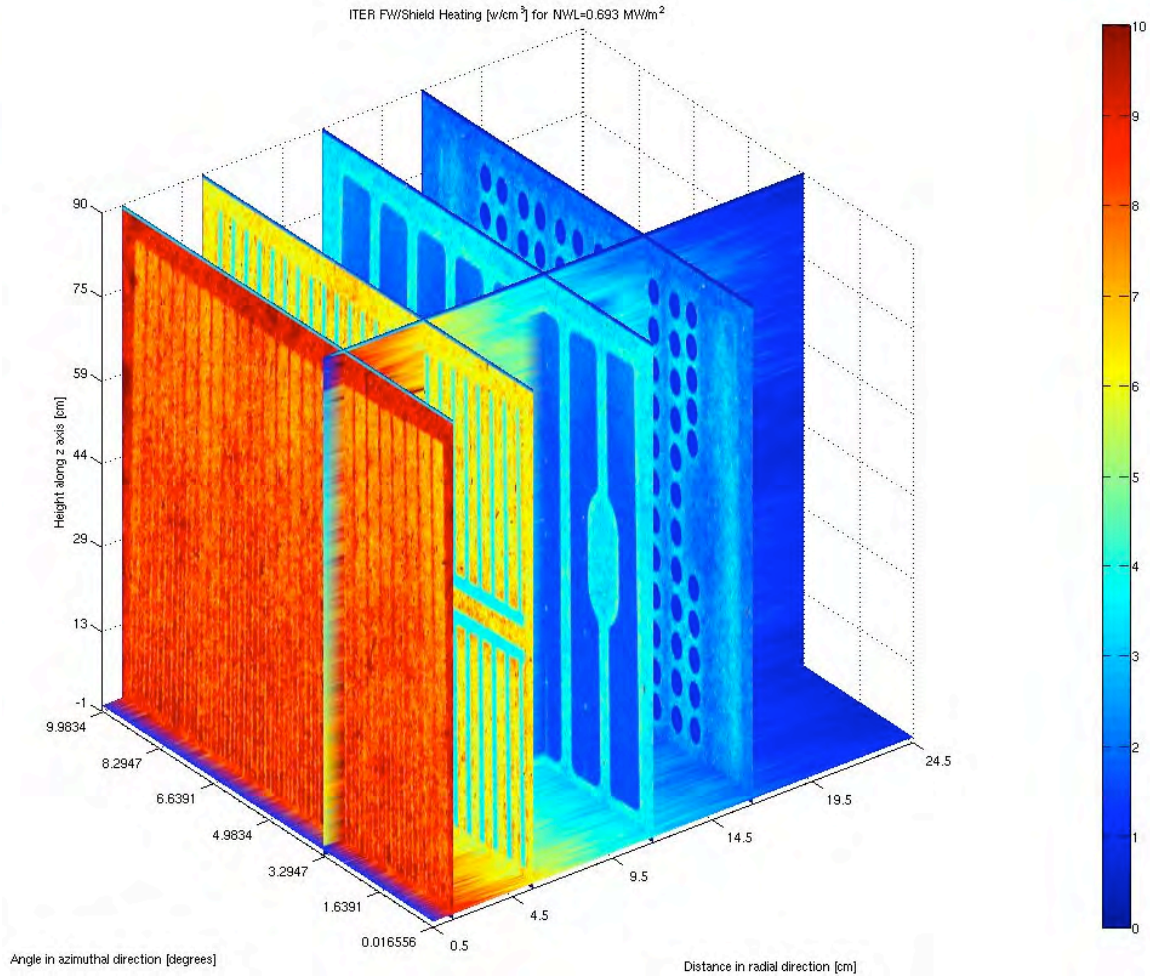

Conclusions

- Nuclear fusion systems are geometrically complex with many components requiring detailed 3-D nuclear analysis
- An innovative calculation method was developed where the 3-D Monte Carlo neutronics calculations are performed directly in the detailed CAD geometrical model
- This eliminates human error, improves accuracy and cuts down turnaround time to accommodate design changes and iterations
- The tool has been successfully tested for an ITER benchmark and applied to perform nuclear analysis for several fusion designs resulting in high fidelity, high-resolution results that significantly improve the design process



Produced by University Communications

Questions?

sawan@engr.wisc.edu

