

# A Novel GUI Modeled Fuzzy Logic Controller for a Solar Powered Energy Utilization Scheme

I. H. Altas<sup>1,\*</sup> and A.M. Sharaf<sup>2</sup>

[ihaltas@altas.org](mailto:ihaltas@altas.org) and [sharaf@unb.ca](mailto:sharaf@unb.ca)

<sup>1</sup>: Dept. of Electrical and Electronics Engineering, Karadeniz Technical University, Trabzon, Turkey

<sup>2</sup>: Dept. of Electrical and Computer Engineering, University of New Brunswick, Canada

\*: Currently a visiting scholar at the University of New Brunswick, Canada

**Abstract**— solar powered electrical systems consist of different parts to be controlled separately. Since the generated power is a function of uncontrollable environmental conditions, it requires extra caution to design controllers that handle unpredictable events and maintain efficient load matching power. In this study, a photovoltaic (PV) solar array model is developed for Matlab/Simulink GUI environment and controlled using a fuzzy logic controller (FLC), which is also developed for GUI environment. The FLC is also used to control the DC load bus voltage at constant value as well as controlling the speed of a PMDC motor as one of the loads being fed. The FLC controller designed for Matlab/Simulink GUI environment has general design criteria's so that it can easily be modified and extended for controlling different systems. The proposed FLC is used in three different parts of the PVA stand alone utilization scheme here. One of these parts is the speed control of the PMDC load, one of the other parts is controlling the DC load bus voltage, and the third part is the maximum power point (MPP) tracking control, which is used to operate the PVA at its available maximum power as the solar insolation and ambient temperature change.

**Index Terms**— Photovoltaic power systems, Power generation, Motor drives, Fuzzy Logic Control, Matlab/Simulink/GUI Modeling, MPPT tracking

## I. INTRODUCTION

The use of new efficient photovoltaic solar cells (PVSCs) has emerged as an important solution in energy conservation and demand-side management during the last decades. Owing to their initial high costs, PVSCs have not yet been an attractive alternative for electricity users who are able to buy cheaper electrical energy from the utility grid. However, they have been used extensively for water pumping and air conditioning in remote and isolated areas where utility power is not available or is too expensive to transport. Although solar cell (SC) prices have decreased considerably during the last years due to new developments in the film technology and manufacturing process [1], PV arrays are still considered rather expensive compared with the utility fossil fuel generated electricity prices. After building such an expensive renewable energy system, the user naturally wants to operate the PV array at its highest conversion efficiency by continuously utilizing the maximum available output power of the array. The electrical system powered by solar cells requires special design considerations because of the varying nature of the solar power generated resulting from

unpredictable changes in weather conditions which affect the solar radiation level as well as the cell operating temperature. Salameh and Dagher [2] have proposed a switching system that changes the cell array topology and connections or the configurations of the cells to get the required voltage during different periods of a day. A steady-state analysis of a scheme employing direct coupling between a series/shunt or separately excited DC motors and the photovoltaic solar arrays has been given by Roger [3]. The dynamic performance of a DC shunt motor-photovoltaic system has been studied by Fam and Balachander [4]. The starting and steady-state characteristics of DC motors powered by a solar cell array source have been studied by Appelbaum [5] to select the suitable parameters and type of DC motor for a desired utilization scheme. All these studies concerning DC motors or permanent magnet (PM) DC motors powered by PV generators have been done by considering the direct interface between the motor load and the PV source generator. For direct coupling of DC motors to solar arrays, the separately excited or PM motors with a ventilator type load are the most suitable [5]. Owing to changes in the solar radiation energy and the cell operating temperature, the output power of a solar array is not constant at all times. Consequently, a maximum solar power tracking controller is always needed in any scheme with solar cell arrays [6, 7] to ensure maximum utilization. Therefore, works to solve the problems on maximum power point tracking (MPPT) have always been a hot topic for PVA utilization systems.

PVA operating schemes consist of mainly four different controlled parts as MPP tracking controller, backup battery charge regulator and controller, load bus voltage controller, and special load controllers. A PVA scheme must be considered as a whole unit since all these parts are tied up together and need to be controlled together. Separate consideration usually results the failure of required operation and affect the system efficiency. Therefore the proposed PVA scheme here consists of three controllers for MPP tracking, load bus voltage and the special load controller such as PMDC motor speed control. The battery backup unit controller here is combined with the MPP tracking controller and is not treated separately.

A fuzzy logic controller is developed to be used in all of the controlled parts of the proposed PVA scheme. The FLC controller is modeled for Matlab/Simulink GUI environment as a simulation block so that it can be moved to be used along with the other parts of the PVA scheme.

## II. PVA UTILITY SYSTEM

As shown in Fig. 1, the proposed PVA utility scheme consists of a PVA, a PMDC motor driving a fan type load, a constant R-L load, a switch able R-L load, a MPPT unit consisting of a switch able back-up battery unit, and a filter circuit. A PMDC motor speed controller unit, a voltage controller unit, and a MPP tracking controller unit are assembled to the scheme. A dc load bus is established with the voltage kept constant using a controlled dc chopper. Actually more dc load buses can be created with different voltage values that kept constant using a dc chopper for each bus as long as the total load power stays between lower and upper power limits and the PVA MPPT operating voltage is equal to or higher than the voltages at the load buses. The voltage at load bus is kept constant because the loads are generally designed to be operated at their predefined rated voltage for safer operation. Some loads may require additional operating conditions such as the PMDC motor shown in Fig. 1. Here, the PMDC motor is operated at different speed levels. Therefore an additional controller is used for only speed control of the PMDC motor. A constant R-L load is connected to the load bus to represent the loads that are operated at constant voltage without any control unit. The PMDC motor and the constant R-L loads are assumed to be the permanent loads to be fed all the time. Optional and additional loads are represented by a switch able R-L load, which is a combination of the similar R-L loads connected/disconnected in parallel with the switching actions. The switch able loads are used to match the load power with the PVA power. If the maximum power generated by the PVA

is grater than the load power currently being used, then some of the switch able loads are connected. Instead of the switch able loads, backup batteries may also be connected using the controlled switching similar to the one described for the switch able loads. However, the battery charging units also include charging regulators for voltage and power matching between the PVA and the back-up batteries. The switching to connect both batteries and the switch able loads to the system are controlled through the MPPT. Depending on the maximum power point operation of the PVA, additional loads or back-up batteries are connected or disconnected from the system. A filter circuit with a series R-L and shunt C is also used to filter current ripples and voltage discontinuities. As long as the voltage at dc load bus is kept constant at desired value, an inverter can be used to convert the dc voltage provided by PVA to ac voltage for connection to the ac utility.

## III. GUI MODELING OF THE PVA

A general block diagram of the PVA model for GUI environment of Simulink is given in Fig. 1. The block called *PVA model for GUI* is the last stage of the model. The other stages of PVA are masked as functional subsystem blocks under the last stage shown in Fig. 1. The first stage of the PVA modeling is depicted in Fig. 2 where the mathematical model [6, 8] of a single PV cell is represented with the block called *Equation 1*. Another block representing the effects of solar insulation and operating temperature is also adopted from [6, 8] and included in Fig.2, which is a sub-mask of the stage 2, given in Fig. 3.

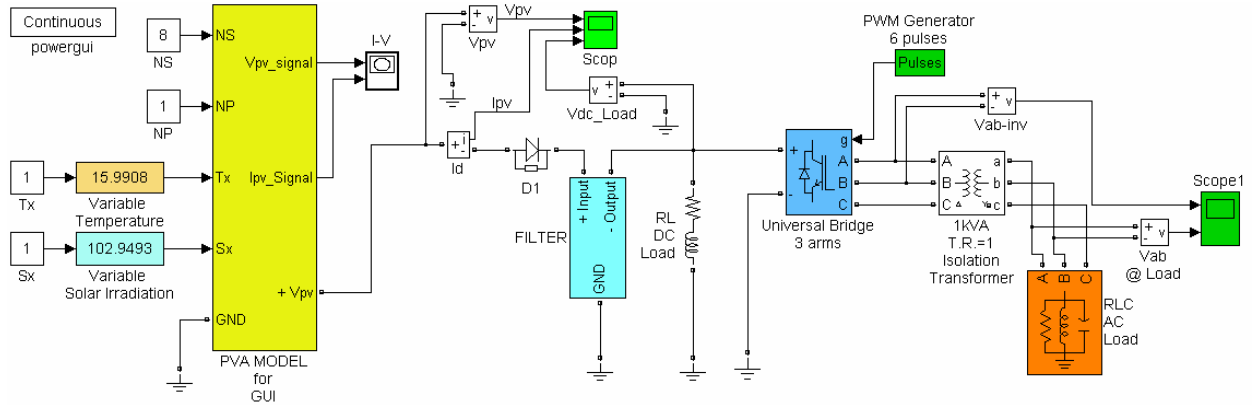

Fig. 2. Operational functional block diagram of the PVA model.

## IV. FLC MODELING IN SIMULINK

It is not intended, here, to give the theoretical background information about fuzzy logic. The process of an FLC can be summarized in three steps: fuzzification, rule based fuzzy processing, and defuzzification. Triangular fuzzy membership functions were used in both fuzzification and defuzzification stages.

Fuzzification stage and the first part of rule based fuzzy processing unit of the FLC is given in Figure 4. The crisp inputs  $e(k)$  and  $\Delta e(k)$  are converted to fuzzy membership values on the fuzzy subsets Negative Big (NB), Negative

Small (NS), Zero (Z), Positive Small (PS), and Positive Big (PB). Each fuzzy subset (FS) is represented by a triangular membership function. The letters E and DE in Fig. 4 are used to indicate whether the elements belong to error or its change DE, respectively.

The Boolean operator “*min*” is used for the verbal connector “*and*” to simulate the *input space of the rules* that have the structure as in expression;

**If**  $e$  is PB **and**  $\Delta e$  is NB **then**  $\Delta u_1$  is NB.

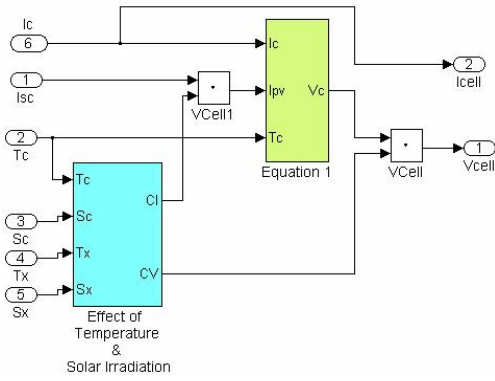

Fig. 3 Modeling stage 1.

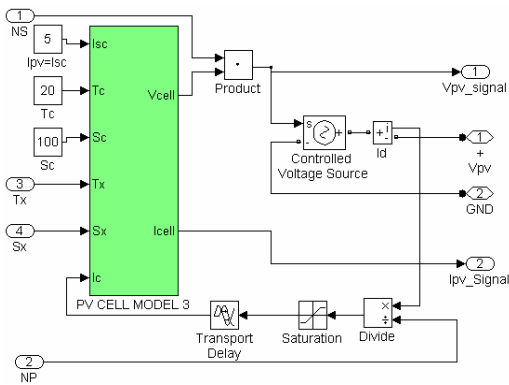

Fig. 4 Modeling stage 2.

The input space in above expression is the part that represented by the expression ( $e$  is PB *and*  $\Delta e$  is NB). Therefore the min operator in Simulink Block Library is used to model the input spaces of 25 rules used by FLC. The outputs of the “min” operators indicate the strength

(membership degree) of the rules in the output space  $\Delta u_1$ . The implementation of the rule input space by the expression ( $e$  is PB *and*  $\Delta e$  is NB) is nothing but the fuzzification of the two crisp inputs  $e$  and  $\Delta e$  for all the rules. The process of fuzzification of the input space with 25 rules is shown in Fig. 4.

Simulation model of the *centre of area* method for defuzzification and reasoning is depicted in Fig. 5. This is the final stage of the FLC to generate the required change in control signal for the current  $k$ th sampling.

## V. SIMULATION RESULTS

The MPP tracing controller is tested by simulating the system given in Fig 1. The speed of the PMDC motor and the load bus voltage are also controlled using a fuzzy logic controller similar to the one explained above. Since rated voltage of the PMDC motor is 36 V, the load bus voltage is kept constant at 40 V. The average value of the output voltage of the chopper is compared with 40 V reference voltage and the difference is used by the controller to generate the required chopper duty cycle so that the dc bus voltage is kept at 40 V. The duty cycle of the chopper for PMDC motor speed control is determined by the speed controller, which is used to keep the motor speed at 200 rad/sec.. The total current drawn by all the loads and backup batteries being charged is the current drawn from the PVA. This total current is divided by the number of PV cells in parallel to find the current of a single cell so that it can be used to simulate PV cell model to generate a voltage, which is then multiplied by the number of the cells in series to obtain the PVA output voltage.

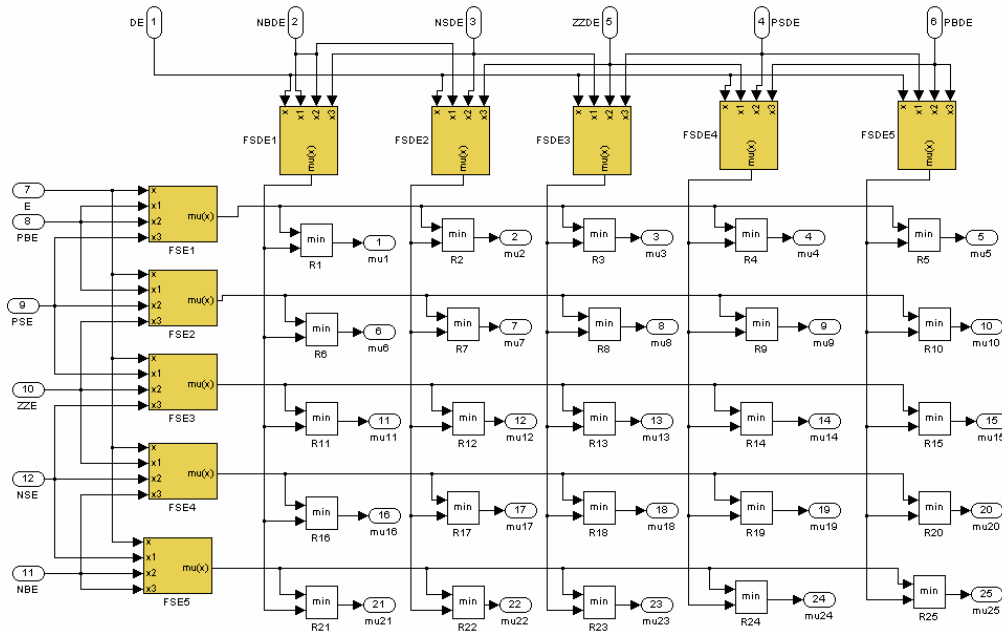

Fig. 4. The Simulink model of the Fuzzification process.

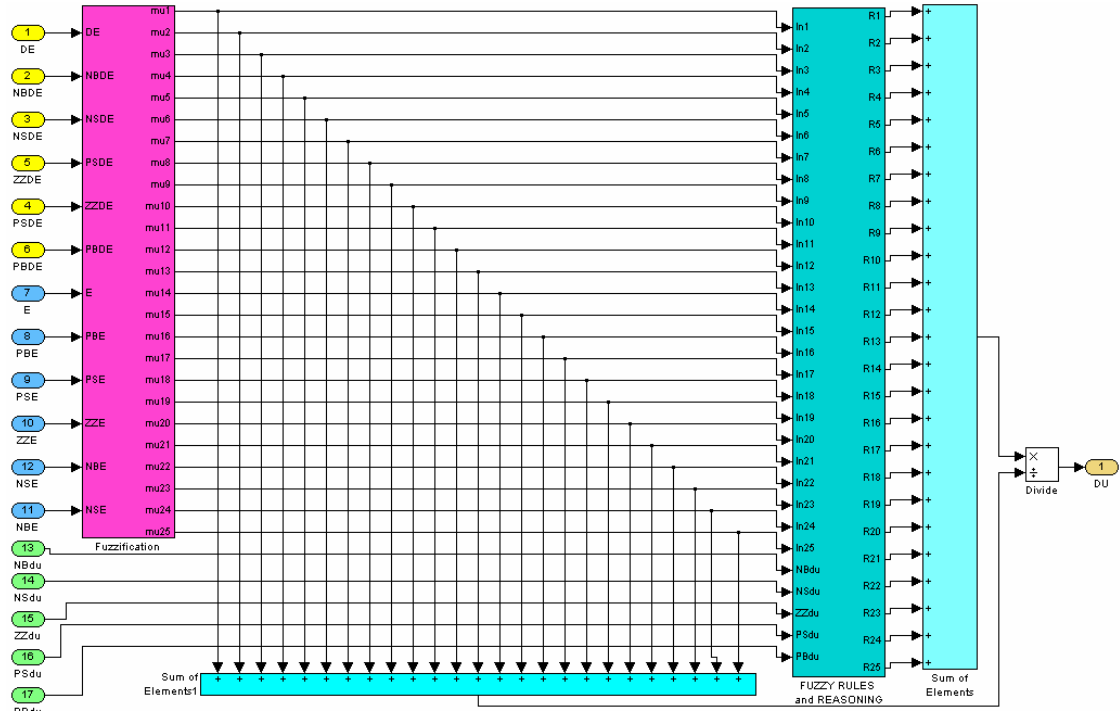

Fig. 5. The process from fuzzification to defuzzification in the FLC block.

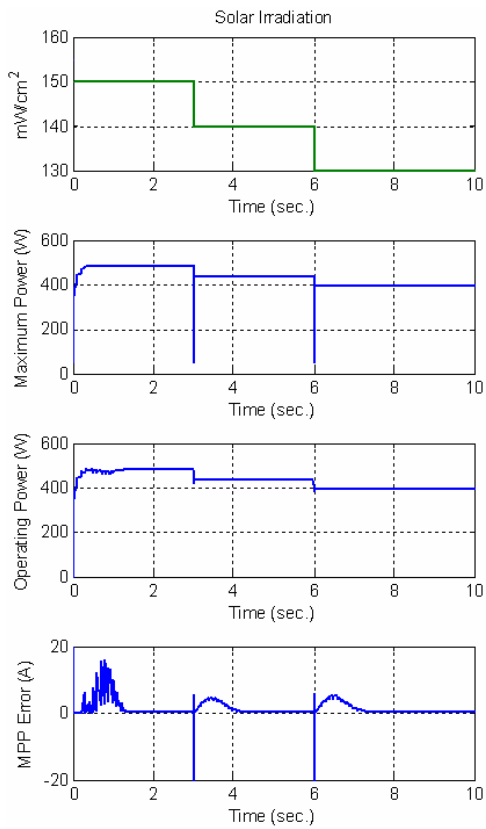

Fig. 6. Variations of the PVA power quantities as the solar irradiation level decreases.

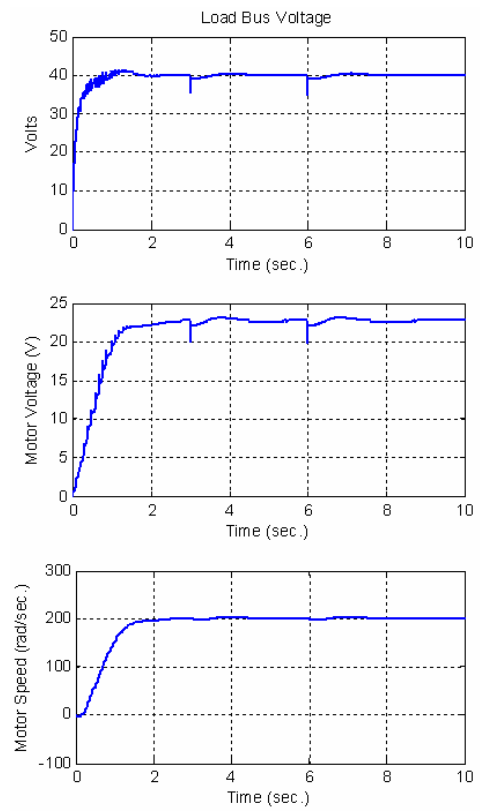

Fig. 7. Variations of the dc load bus voltage, PMDC motor voltage, and the motor speed as the solar irradiation level decreases.

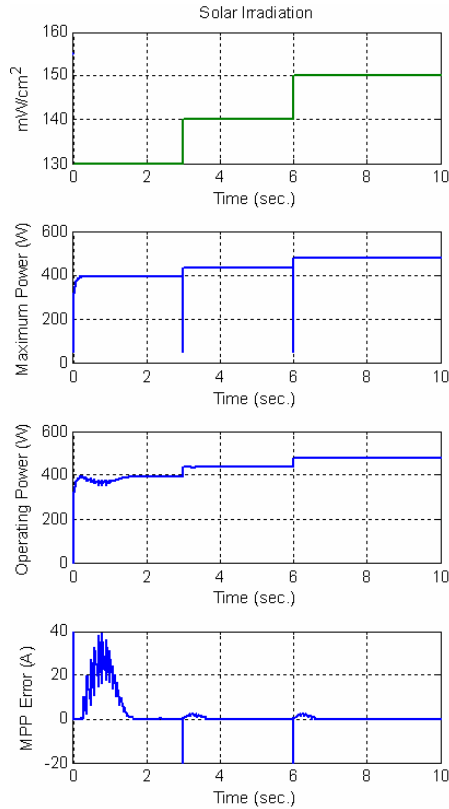

Fig. 8. Variations of the PVA power quantities as the solar irradiation level increases.

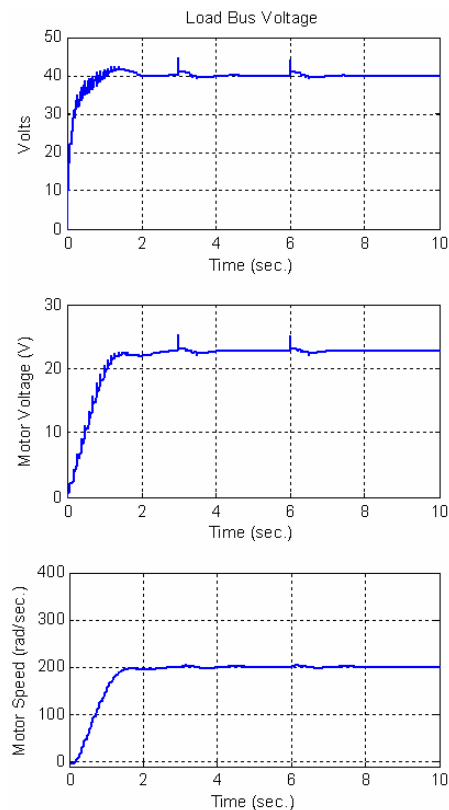

Fig. 9. Variations of the dc load bus voltage, PMDC motor voltage, and the motor speed as the solar irradiation level decreases.

## VI. CONCLUSIONS

This paper introduces a novel Matlab/Simulink unified Functional Block Model and a novel but simple FLC model for use in Matlab/Simulink GUI environment. The maximum power point MPP-Search and Detection algorithm is dynamic in nature and operates without any required measurement or forecasted PV array information about the irradiation and temperature. The proposed FLC GUI model can be used in different stages of the PVA scheme to control both MPP trackers, load bus voltage and load motor speed. Simulation results show acceptable MPP tracking as well as voltage and speed control responses.

## VII. REFERENCES

- [1]. M. Buresch, *Photovoltaic Energy Systems Design and Installation*, McGraw-Hill, New York, 1983.
- [2]. Z. M. Salameh and F. Dagher, The effect of electrical array reconfiguration on the performance of a PV powered volumetric water pump, *IEEE Trans., EC-5* (1990) 653-658.
- [3]. J. A. Roger, Theory of the direct coupling between DC motors and photovoltaic solar arrays, *Solar Energy*, 23 (1979) 193-198.
- [4]. W. Z. Faro and M. K. Balaehander, Dynamic performance of a DC shunt motor connected to a photovoltaic array, *IEEE Trans., EC-3* (1988) 613-617.
- [5]. J. Appelbaum, Starting and steady-state characteristics of DC motors powered by solar cell generators, *IEEE Trans., EC-1* (1986) 17-25.
- [6]. I. H. Altas and A. M. Sharaf, A solar powered permanent magnet DC motor drive scheme, *Proc. 17th Annu. Conf. Solar Energy Soc. Canada, Toronto, Ont., Canada, 1991*, pp. 65-71.
- [7]. A. M. Sharaf and L. Wang, A photovoltaic powered efficient DC motor drive for pump irrigation, *Proc. Canad. Solar Energy Conf., Halifax, N.S., Canada, 1990*.
- [8]. I. H. Altas and A. M. Sharaf, "A Fuzzy Logic Power Tracking Controller For A Photovoltaic Energy Conversion Scheme", *Electric Power Systems Research Journal*, Vol.25, No.3, pp.227-238, 1992.