

The Fixed Bed Nuclear Reactor Concept

Sümer ŞAHİN

Gazi University, Teknik Eğitim Fakültesi, Ankara, Turkey

sumer@gazi.edu.tr

Farhang SEFIDVASH

Federal University of Rio Grande do Sul, Porto Alegre, Brazil

farhang@ufrgs.br

ABSTRACT

In the present work, the basic features of a new reactor type, the so called Fixed Bed Nuclear Reactor (FBNR) is presented. FBNR is a small reactor (40 MWe) without the need of on-site refueling. It utilizes the PWR technology but uses the HTGR type fuel elements. It has the characteristics of being simple in design, modular, inherent safety, passive cooling, proliferation resistant, and reduced environmental impact.

The study comprises reactor description, fuel element description, criticality calculations. A series of one dimensional criticality calculations are conducted with SCALE5 using S_N methods. S_N calculations with SCALE5 have resulted for the cold reactor (20 °C, 1 bar) $k_\infty = 1.4408$ and for the hot reactor (308 °C, 160 bar), based on the average inlet-outlet temperatures, $k_\infty = 1.40003$ for the spherical fuel element cell. Time calculations have been pursued for 12 years.

Three dimensional criticality calculations benchmarking are conducted with MCNP5-1.4 using Monte Carlo methods and have yielded $k_{\infty} = 1.45673$ for the hot FBNR unit cell.

KEYWORDS: Advanced reactors, spherical fuel, coated particle fuel, fluidized bed

1 INTRODUCTION

The Small Reactors without On-Site Refueling are defined by IAEA “As reactors which have a capability to operate without refueling and reshuffling of fuel for a reasonably long period consistent with the plant economics and energy security, with no fresh and spent fuel being stored at the site outside the reactor during its service life. They also should ensure difficult unauthorized access to fuel during the whole period of its presence at the site and during transportation, and design provisions to facilitate the implementation of safeguards. In this context, the term “refueling” is defined as the ‘removal and/or replacement of either fresh or spent, single or multiple, bare or inadequately confined nuclear fuel cluster(s) or fuel element(s) contained in the core of a nuclear reactor’. This definition does not include replacement of well-contained fuel cassette(s) in a manner that prohibits clandestine diversion of nuclear fuel material.“ FBNR [1-3] is designed to be such a reactor and to meet the requirements for an innovative reactor established by the IAEA-INPRO Program [4].

2 REACTOR DESCRIPTION

The Fixed Bed Nuclear Reactor (FBNR) is a small reactor (40 MWe) without the need of on-site refueling. It utilizes the PWR technology but uses the HTGR type fuel elements. It has the characteristics of being simple in design, modular, inherent safety, passive cooling, proliferation resistant, and reduced environmental impact.

The fixed bed concept is a special case of the fluidized bed concept. Here, the fuel elements (pebbles) are fixed in the core through the pressure put on them by the flow (~ 10 bar). The pebbles become fluidized in the fuel chamber and leave the chamber when the velocity reaches ~ 1.4 m/sec and go to the core where they stay in a fixed position while the flow velocity is ~ 7 m/sec.

The FBNR is modular in design, and each module is assumed to be fuelled in the factory. The fuelled modules in sealed form are then transported to and from the site. The FBNR has a long fuel cycle time and, therefore, there is no need for on-site refueling. The reactor makes an extensive use of PWR technology.

It is an integrated primary system design. The basic modules have in its upper part the reactor core and a steam generator and in its lower part the fuel chamber, as shown in the schematic figure 1. The core consists of two concentric perforated zircaloy tubes of 20 cm and 160 cm in diameters, inside which, during the reactor operation, the spherical fuel elements are held together by the coolant flow in a fixed bed configuration, forming a suspended core, figure 2. The coolant flows vertically up into the inner perforated tube and then, passing horizontally through the fuel elements and the outer perforated tube, enters the outer shell where it flows up vertically to the steam generator. The reserve fuel chamber is a 40-cm diameter tube made of high neutron absorbing alloy, which is directly connected underneath the core tube. The fuel chamber consists of a helical 25 cm diameter tube flanged to the reserve fuel chamber that is sealed by the international authorities. A grid is provided at the lower part of the tube to hold the fuel elements within it. A steam generator of the shell-and-tube type is integrated in the upper part of the module. The control rods slide inside the core. The reactor is provided

with a pressurizer system to keep the coolant at a constant pressure. The pump circulates the coolant inside the reactor moving it up through the fuel chamber, the core, and the steam generator. Thereafter, the coolant flows back down to the pump through the concentric annular passage. At a certain pump velocity, the water coolant carries up the 15 mm diameter spherical fuel elements from the fuel chamber into the core. A fixed suspended core is formed in the reactor. In a shut down condition, the suspended core breaks down and the fuel elements leave the core and fall back into the fuel chamber. The fuel elements are made of TRISO type micro spheres used in HTGR.

The control system is based on the inherent safety philosophy that when all the signals from all the detectors are within the design ranges, the pump can operate, thus the normal situation of pump is “off” position.. Therefore, any initiating event will cut-off power to the pump, causing the fuel elements to leave the core and fall back into the fuel chamber, where they remain in a highly sub critical and passively cooled condition. The fuel chamber is cooled by natural convection transferring heat to the water in the tank housing the fuel chamber.

The pump circulates the water coolant in the loop and at the mass flow rate of about 141 kg/sec, corresponding to the terminal velocity of 1.64 m/sec in the reserve fuel chamber, carries the fuel elements into the core and forms a fixed bed. At the operating mass flow rate of 668 kg/sec, the fuel elements are firmly held together by a pressure of 10 bar forming a stable fixed bed. The coolant flows radially in the core and after absorbing heat from the fuel elements enters the integrated heat exchanger of tube and shell type. Thereafter, it circulates back into the pump and the fuel chamber. The long-term reactivity is supplied by fresh fuel addition and a fine control rod that moves in the center of the core controls the short-term reactivity. A piston type core limiter adjusts the core height and controls the amount of fuel

elements that are permitted to enter the core from the reserve chamber. The control system is conceived to have the pump in the “not operating” condition and only operates when all the signals coming from the control detectors simultaneously indicate safe operation. Under any possible inadequate functioning of the reactor, the power does not reach the pump and the coolant flow stops causing the fuel elements to fall out of the core by the force of gravity and become stored in the passively cooled fuel chamber. The water flowing from an accumulator that is controlled by a multi redundancy valve system cools the fuel chamber as a measure of emergency core cooling system. The other components of the reactor are essentially the same as in a conventional pressurized water reactor.

The new safety feature is now the following: In case of any abnormality (e.g. external power failure, overheating etc.) the circulating pump stops and – due to gravity – the fuel pellets fall automatically out of the core region into a helical “fuel chamber” underneath the core where their decay heat is transferred passively by natural circulation to a water tank housing the fuel chamber. The safety principle, applied here, is: The loss of an active component (circulating pump) induces a self-controlled, passively working shut-down maneuver accompanied by a foolproof decay heat removal without any emergency power system or any human interaction.

3 FUEL ELEMENT DESCRIPTION

Coated particle fuel has been used for more than 30 years in nuclear reactors. These reactors have benefited from this fuel’s higher burn up and temperature capabilities and its multiple barriers to fission product release. The use of a particle fuel form in LWRs has the potential to significantly increase burn up, safety margin, and proliferation resistance. In addition, it

will reduce the fission product release relative to the present clad UO_2 fuels. Using a coated particle fuel form tailored to a water-reactor environment can eliminate the constraints of the present pressurized water reactor (PWR) fuel system. Particle fuel reduces fuel temperatures, lowers stored energy, and has better fission product retention.

One of the significant features of the coated particle fuel form is the vast increase in surface area per fuel volume over the commonly used pellet and clad fuel.

Under any thinkable operational condition the fuel temperature will be below $400\text{ }^\circ\text{C}$ whereas its stability limit is at about $1600\text{ }^\circ\text{C}$. The first characteristic of the FBNR is, therefore, its robust fuel under relatively “cold” operating conditions and – due to the outer SiC – shell layer – the freedom from any hydrogen production.

Coated particle nuclear fuel has been irradiated to more than ten times higher than the present LWR range. This allows much greater energy extraction from the same amount of fuel, which results in less fuel throughput per energy produced. The reduction in spent fuel minimizes the burden on both temporary and permanent storage of spent fuel. This increase in burn up can also be used to provide longer fuel cycles, which is a significant benefit in refueling reactors in remote locations or countries with modest infrastructure.

3.1 Numerical Calculations

SCALE (Standardized Computer Analyses for Licensing Evaluation) is a modular code system that is used for reactivity calculations [5]. The SCALE5 system makes neutron transport calculations in $\text{S}_8\text{-P}_3$ approximation by solving the Boltzmann transport equation in

one-dimensional geometry with the transport code XSDRNPM using the 238-neutron group's data library, derived from ENDF/B-V. The library has 148 fast and 90 thermal (above 3 eV) groups, and enables very fine energy resolution for multi-group neutron transport calculations. The resonance self-shielding weighted cross-sections have been processed with the help of the CSAS control module using BONAMI for unresolved resonances and NITAWL-III for resolved resonances.

Figure 3 shows the geometrical modeling of the reactor core and reflector for numerical calculations.

S_N calculations with SCALE5 have resulted

- for the cold reactor (20 °C, 1 bar)

$k_\infty = 1.4408$ for the spherical fuel element cell, $k_{\text{eff}} = 1.3444$ for the reactor for a cylinder height of = 180 cm and $k_{\text{eff}} = 1.3473$ for the reactor for a cylinder height of = 200 cm. The axial leakage for different core height has been considered through pseudo absorption with the help of axial buckling.

- and for the hot reactor (308 °C, 160 bar), based on the average inlet-outlet temperatures

$k_\infty = 1.40003$ for the spherical fuel element cell, $k_{\text{eff}} = 1.2743$ for the reactor for a cylinder height of = 180 cm and $k_{\text{eff}} = 1.2785$ for the reactor for a cylinder height of = 200 cm.

The neutron spectra in three main reactor regions for the hot reactor are shown in figure 4.

For benchmarking purposes, MCNP5-1.4 [6] calculations are conducted for the FBNR unit cell. Figure 5 shows the MCNP5-1.4 modeling of the FBNR unit cell, where the heterogenous structure of the fuel element considered with utmost precision. Fuel zone radius in the fuel element is $r = 1.3$ cm. SiC clad thickness is 0.1 cm. Fuel particles are placed cubic-centered. Table II depicts the composition of a fuel particle in the FBNR unit cell. Figure 6 shows one fuel particle in the graphite matrix.

Three dimensional criticality calculations with MCNP5-1.4 for the hot FBNR unit cell have yielded $k_{\infty} = 1.45673$. This value can be considered more or less consistent with the one dimensional S_N calculations, conducted with SCALE5. Hence, further calculations have been pursued with the latter code because it allows to conduct rapidly a series of calculations.

In the second phase of the investigations, time dependant criticality studies are performed for the unit spherical fuel element cell. The temporal variations of the atomic densities N of the fissionable fuel components in a fuel bundle during reactor operation are evaluated according to Eqs. (2) and (3) for discrete time intervals Δt , under consideration of the nuclear reactions and radio-active transformation processes, as shown in figure 7.

Atomic density variations in the course of breeding reactions:

$$+ \Delta N_d = \Delta t \cdot N_{m1} \int \sigma_{b,m1}(E) \cdot \Phi(E) \cdot dE + \Delta t \cdot \lambda_{m2} \cdot N_{m2} \quad (2)$$

Indices denote daughter (d) and mother (m) isotopes

Atomic density variations in the course of depletion reactions

$$- \Delta N = \Delta t \cdot N \cdot \int \sigma_{dep}(E) \cdot \Phi(E) \cdot dE + \Delta t \cdot \lambda \cdot N \quad (3)$$

Equations (2) and (3) consider the variations of the atomic number densities of the fissionable nuclides by nuclear transmutations and radioactive decay. The atomic densities have been calculated, considering spatial variations in the neutron spectrum and the atomic densities of all fissionable isotopes over the radial coordinate in the fuel bundle for a time interval of $\Delta t = 10$ days.

Time calculations are extended over 12 years of full power reactor operation. Figure 8 shows the temporal variation of k_{∞} of the unit spherical fuel element cell and the fuel burn-up grade for FBNR fuel element. By considering a reserve reactivity of $\Delta k = 0.1$ to 0.15 , one can see that an operation period of 6 to 8 years would be possible with the same fuel element, where burn up value between 30 to 40 GW.D/MT would be achievable. On the other hand, it should be possible to extend the core-life-time to ~ 10 years if one would decide to use burnable poisons, such as Gd_2O_3 . However, these investigations are out of the scope of the present study.

Figure 9 shows the density variations of the main fissionable isotopes in the FBNR fuel element. Figure 10 depicts the temporal variation of the accumulated densities of fissile isotopes ($^{235}U + ^{239}Pu + ^{241}Pu$) in the FBNR fuel element.

3.2. Reactivity of the reactor as a function of core height and enrichment

The increase in the bed height comes about when the piston like core level controller is lifted up and more pebbles are allowed to enter in the core. This will cause an increase in the global neutron multiplication factors k_{eff} . Figure 11 shows how k_{eff} varies with core height for selected different enrichments of 2.2 %, 5 %, 9 % and 19 %. Up to about 120cm, the core

height has a significant influence on the reactivity, but the variation is low for core heights in the range of 120cm to 250cm.

The fuel chamber is sealed and is transported as the only reactor component to and from the reactor site. There is no possibility to irradiate fertile fuel, too. For a long-life core (larger than a 10 years cycle time) the fuel can either be poisoned by gadolinium-oxide or by a piston type core limiter adjusting the height and controlling thereby the number of the fuel pellets in the active core region. Refueling is done only by changing the fuel chamber allowing also the use of this foolproof light water reactor in countries without a perfect nuclear infrastructure.

4 CONCLUSIONS

The preliminary neutronics calculations show that the expected behavior of the FBNR is similar to a conventional PWR. The core lifetime can be as long as 17 years should the customer being ready to pay for the fuel of 19 % enrichment. The 9 % enrichment provides a lifetime of 7 years. In practice, this is not necessary as the reactor design involves the existence of small fuel chamber that can easily be changed. A 5 % enriched reactor will require a change of fuel chamber only once every 3 years. The refueling involves the connecting and disconnecting of a 5 m³ fuel chamber to the reactor by a flange that is sealed by the safeguard authorities. This simplifies the safeguard procedures and helps the non-proliferation resistance.

In a conclusion FBNR is a completely new pressurized water reactor, based on a robust fuel and a purely passively working decay heat removal system. Aside from electricity production

in the realm of 10-60 MW (electrical) it can also be used for water desalination and space heating purposes.

Future work must cover calculations on void coefficient, Doppler Effect, etc. A qualitative analysis indicates that the moderator to fuel ratio of FBNR is less than in a conventional PWR, therefore, the spectrum will be harder. Generation of voids, make the spectrum still harder but at the same time reduce neutron absorbing water. However, these considerations are out of the scope of the present work.

REFERENCES

- [1] FBNR site: www.rcgg.ufrgs.br/fbnr.htm
- [2] Sefidvash, F. "Fixed Bed Suspended Core Nuclear Reactor Concept", Kerntechnik, 68 (2003) 56-59, February 2003.
- [3] Sefidvash, F. "Fixed Bed Nuclear Reactor (FBNR)" Status of Small Reactor Designs Without On-Site Refuelling 2007, IAEA-TECDOC-1536, pp.373-386, January 2007.
- [4] Methodology for the assessment of innovative nuclear reactors and fuel cycles Report of Phase 1B (first part) of the International Project on Innovative Nuclear Reactors and Fuel Cycles (INPRO) – IAEA-TECDOC 1434
- [5] Petrie, L. M., 2004. SCALE5-Scale System Driver, NUREG/CR-0200, Revision 7, Volume III, Section M1, ORNL/NUREG/CSD-2/V3/R7, Oak Ridge National Laboratory.

[6] X-5 Monte Carlo Team, 2005. MCNP5 - A General Monte Carlo, N-Particle Transport Code, Version 5, LA-CP-03-0245, Los Alamos National Laboratory.

ACKNOWLEDGEMENT

The authors would like to thank the IAEA for its continuing financial support under the Research Contract No. 12960/R0.

The authors thank also to Prof. Dr. Walter Seifritz/Switzerland for his continuous interest in the subject matter, for his valuable comments and for presenting the paper at the ICENES2007.

Table I:
Volume fraction (%) of the materials in a FBNR module.

	UO ₂	H ₂ O	C	Steel	Zircaloy	SiC	Fuel	Total
Region 1	0	95	0	0	5	0	0	100%
Region 2	11.58	40	21.12	0	0	27.3	60	100%
Region 3	0	95	0	5	1	0	0	100%

- | |
|---|
| <ul style="list-style-type: none"> - Stainless steel with a density of 7.758 g/cm³ is composed of 67.84% Fe, 10.86% Ni, 19.22% Cr, 1.88% Mn, and 0.20% Si. - Zircaloy with a density of 5.874 g/cm³ is composed of 99.69% Zr, 0.21% Fe, and 0.10% Cr. - Region 3 does not include pressure vessel. |
|---|

Table II : Composition of the fuel particle (2 mm diameter)

Material	Density (g/cm³)	D_{inside} (cm)	D_{outside} (cm)	Volume (cm³)	Mass (gr)
UO₂	10.5	0	0.158	0.002065237	0.021684988
PYC (porous)	1	0.158	0.176	0.000789306	0.000789306
PYC (dense)	1.8	0.176	0.18	0.000199085	0.000358353
SiC	3.17	0.18	0.2	0.001135162	0.003598464
Average for micro sphere	6.3099629		0.2	0.00418879	0.026431111

FIGURE CAPTIONS

Figure 1. Schematic Design of FBNR

Figure 2. The basic geometrical sketch of the FBNR core

Figure 3. Geometrical modeling of for one dimensional numerical calculations

Figure 4. Neutron spectrum in the reactor

Figure 5. MCNP5 modeling of the FBNR unit cell.

Figure 6. A typical fuel particle in the MCNP5 modeling of the FBNR unit cell

Figure 7. Major nuclear reactions and radioactive transformation processes in the course of reactor operation

Figure 8. Temporal variation of the lattice criticality k_{∞} and the fuel burn-up grade for FBNR fuel element

Figure 9. Density variations of the main fissionable isotopes in the FBNR fuel element

Figure 10. Temporal variation of the accumulated densities of fissile isotopes ($^{235}\text{U} + ^{239}\text{Pu} + ^{241}\text{Pu}$) in the FBNR fuel element

Figure 11. Variation of height for different enrichment values

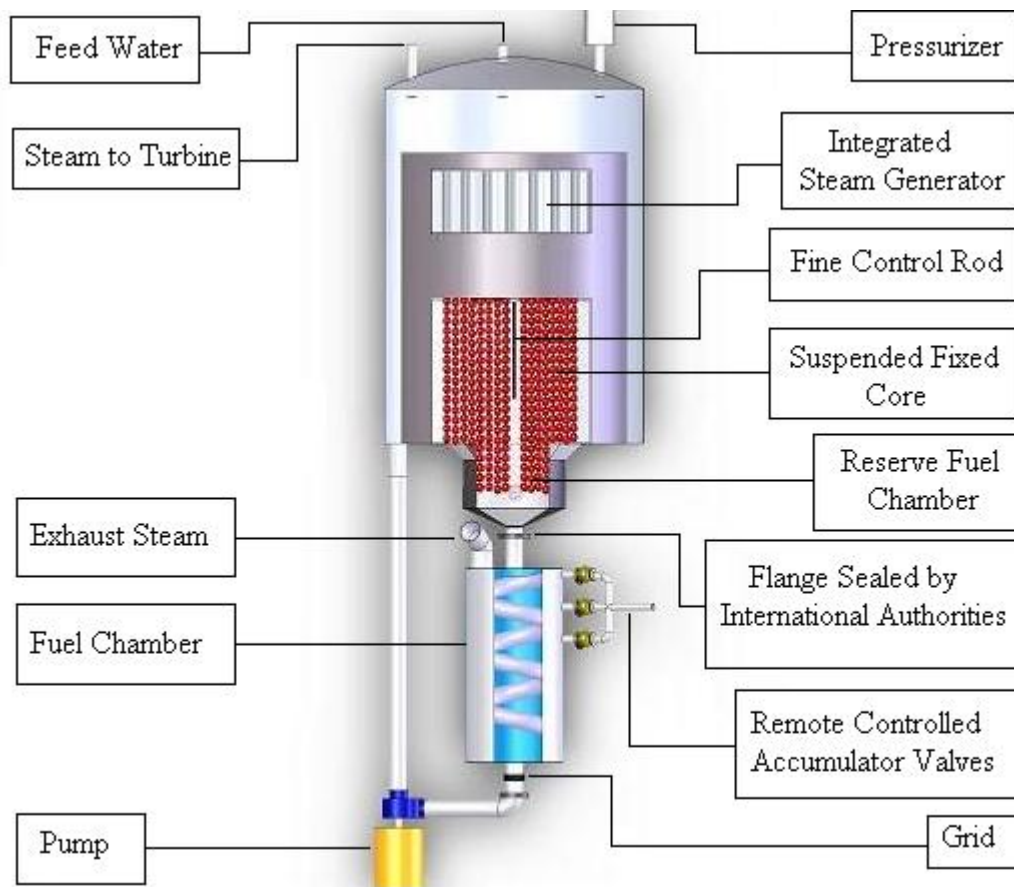

Figure 2. Schematic Design of FBNR

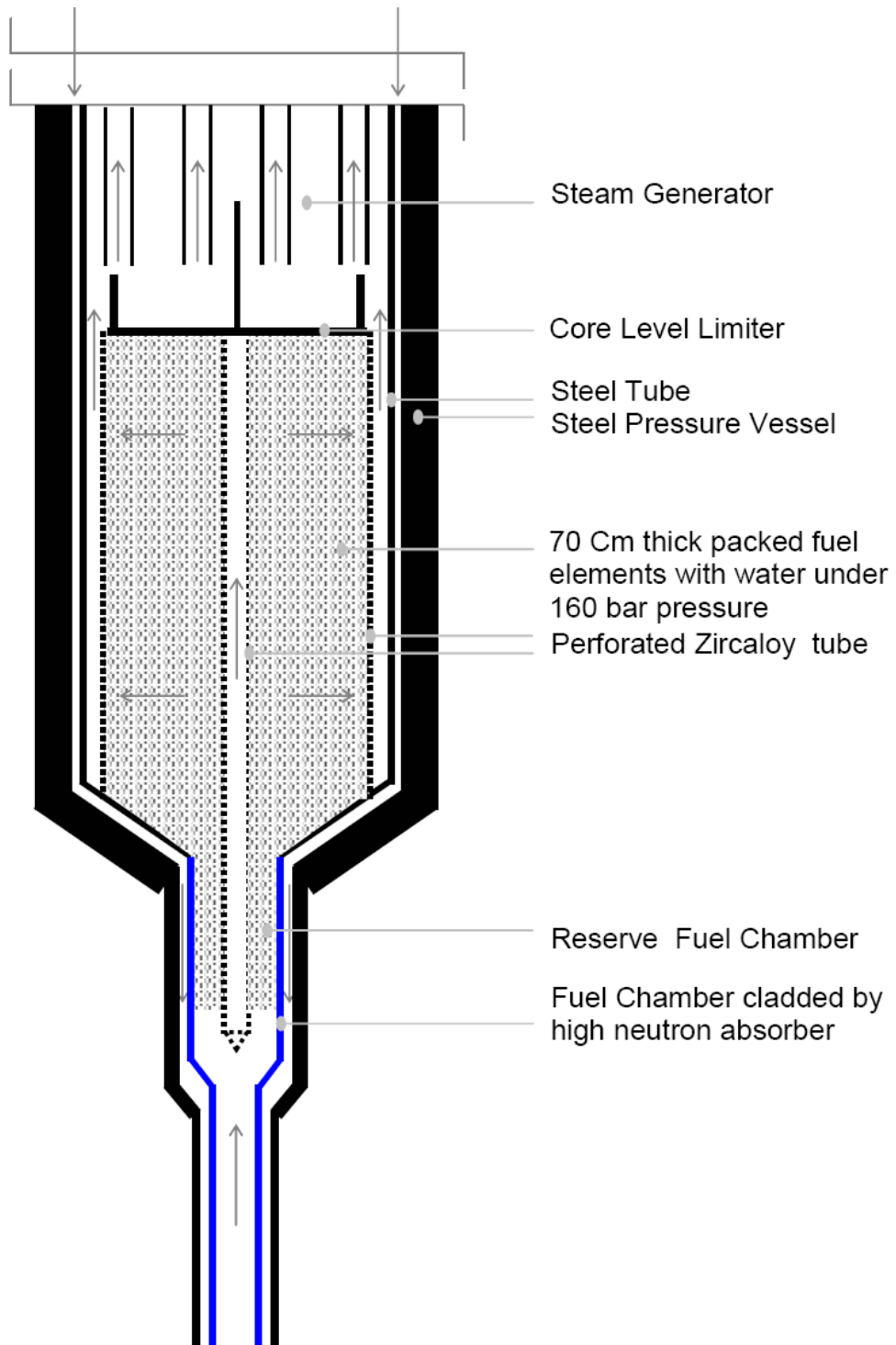

Figure 2. The basic geometrical sketch of the FBNR core

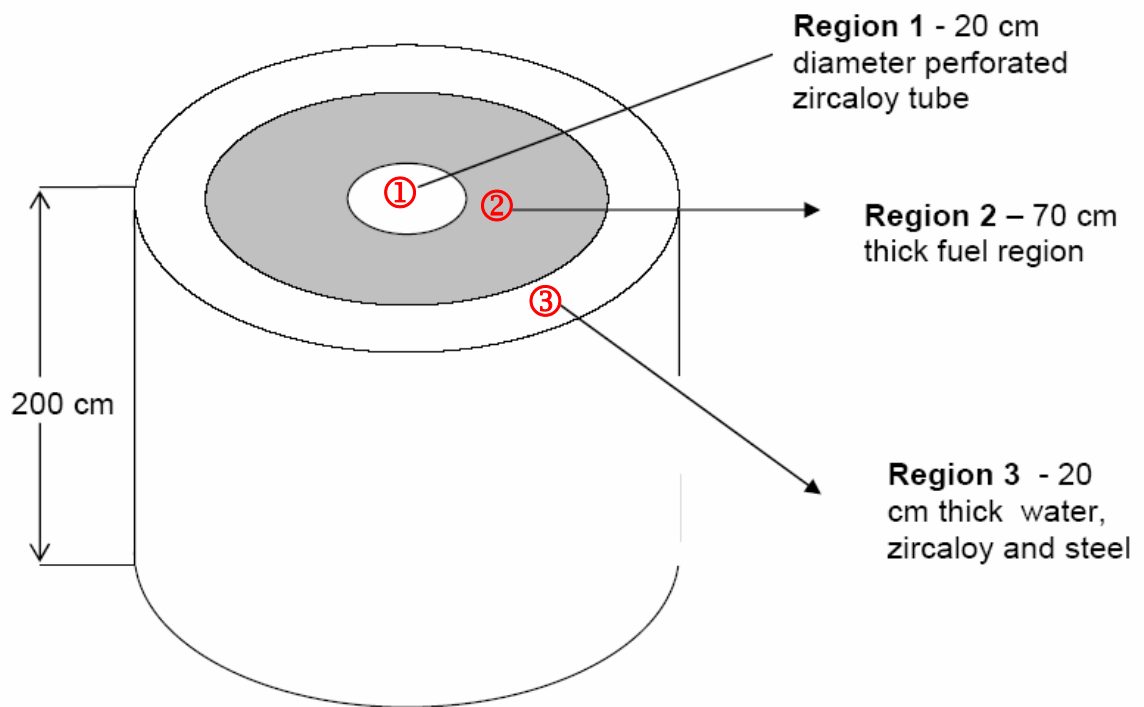

Figure 3. Geometrical modeling of for one dimensional numerical calculations

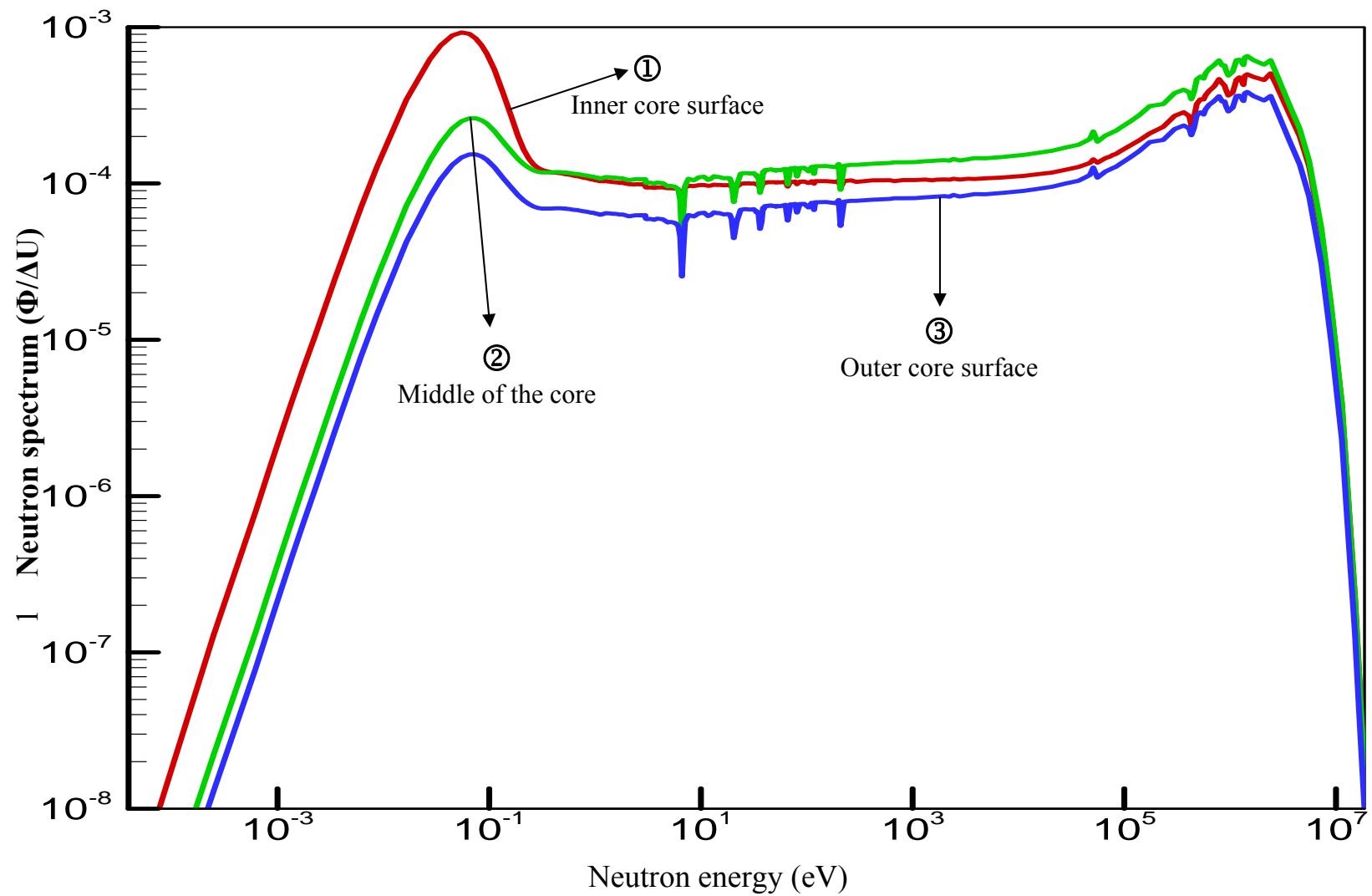

Figure 4. Neutron spectrum in the reactor

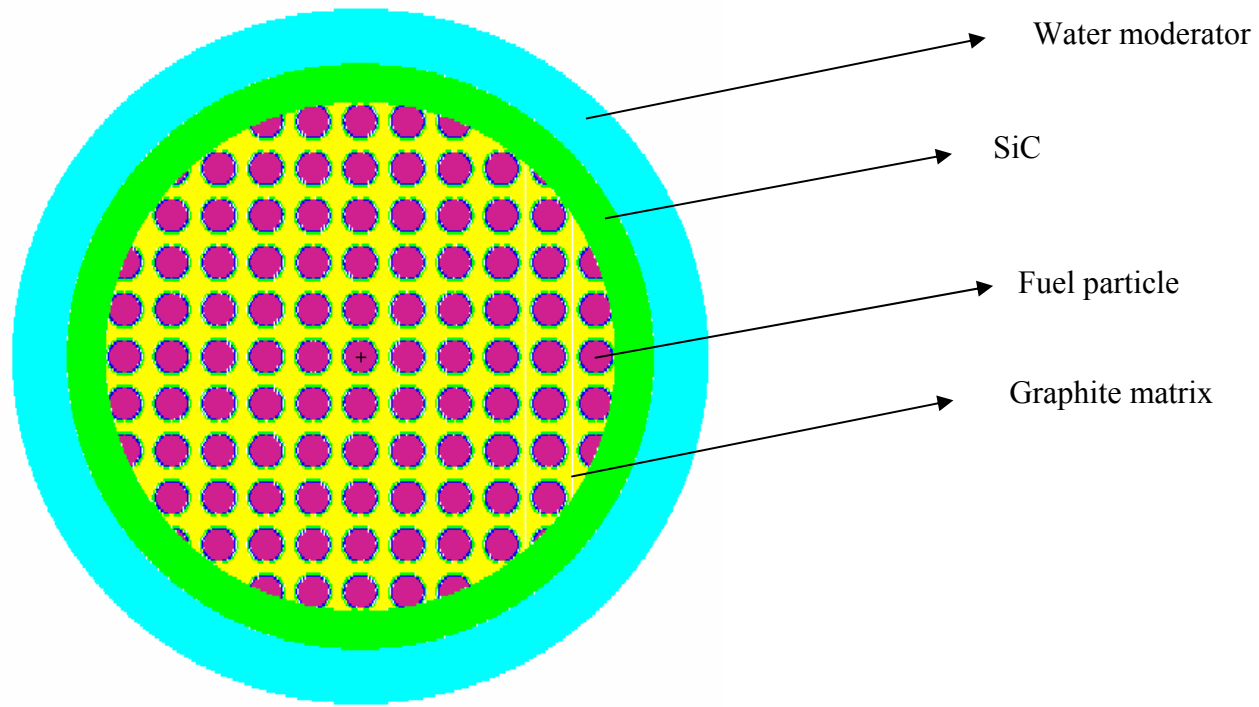

Figure 5. MCNP5 modeling of the FBNR unit cell

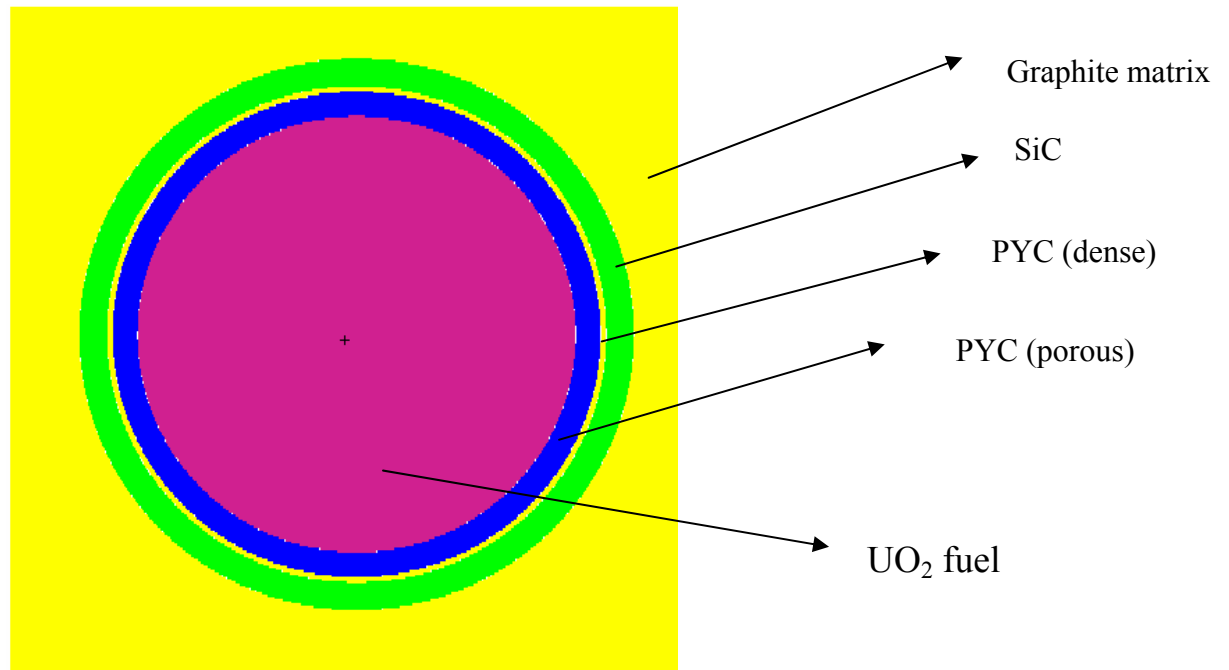

Figure 6. A typical fuel particle in the MCNP5 modeling of the FBNR unit cell

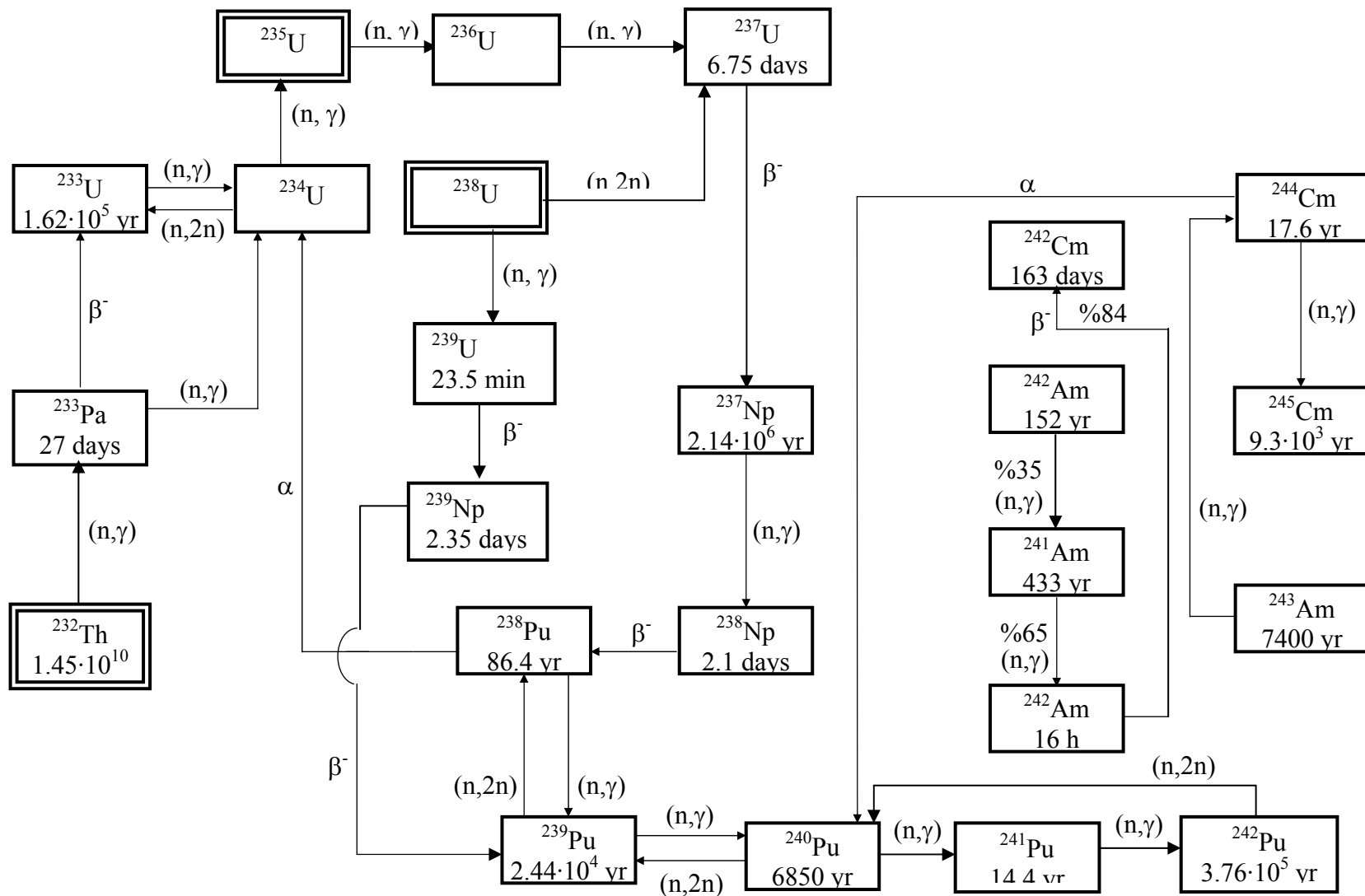

Figure 7. Major nuclear reactions and radioactive transformation processes in the course of reactor operation

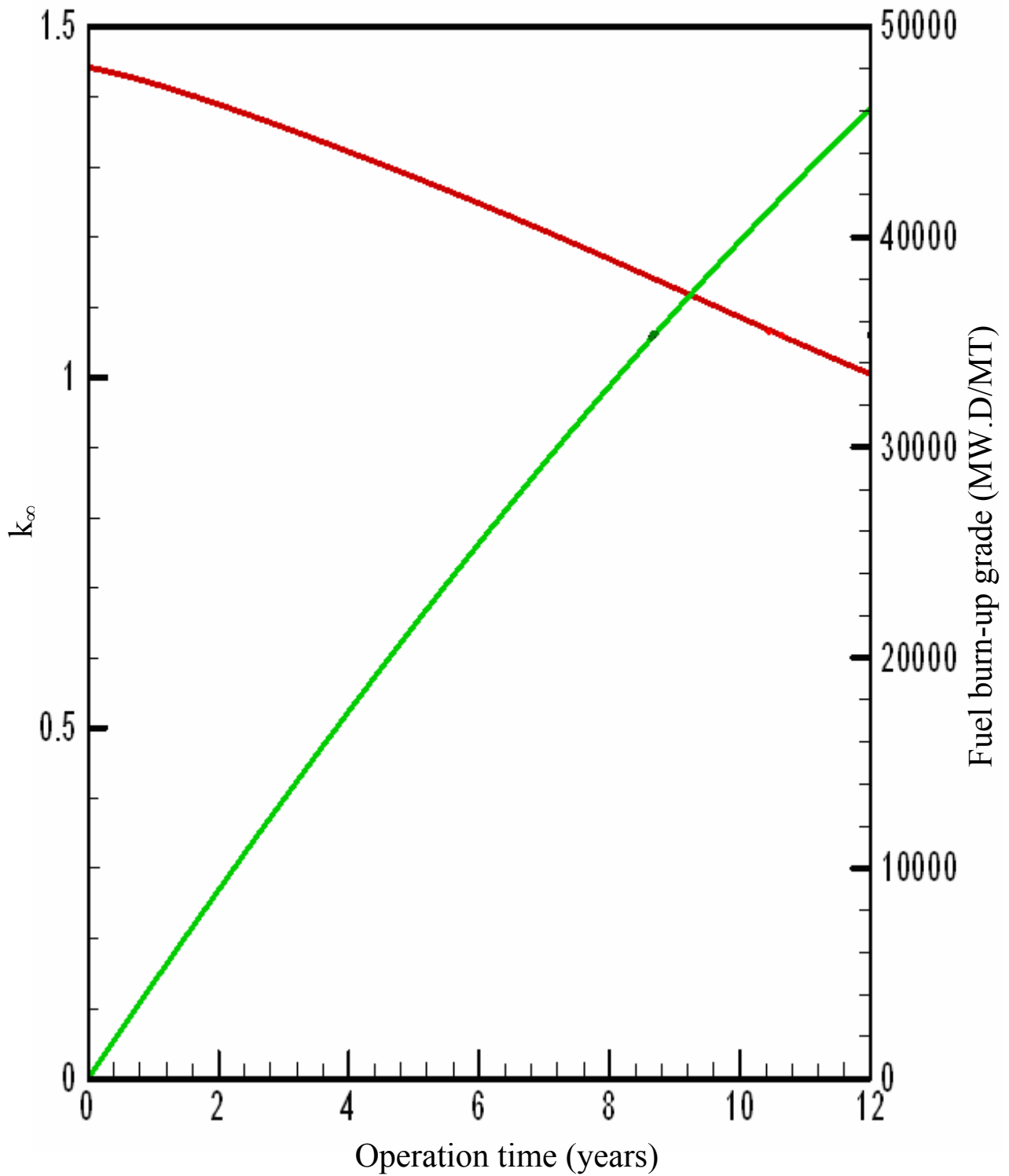

Figure 8. Temporal variation of the lattice criticality k_{∞} and the fuel burn-up grade for FBNR fuel element

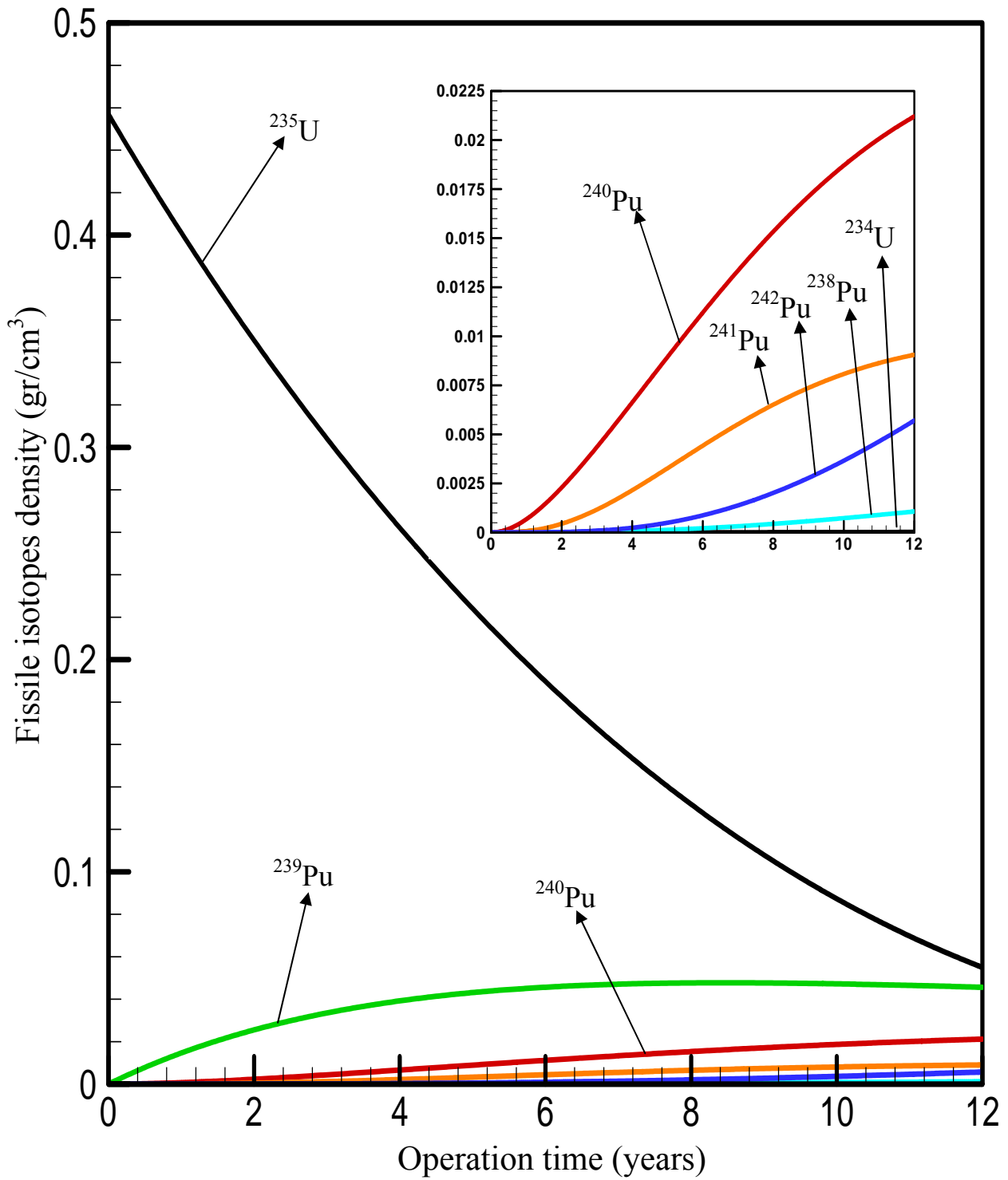

Figure 9. Density variations of the main fissionable isotopes in the FBNR fuel element

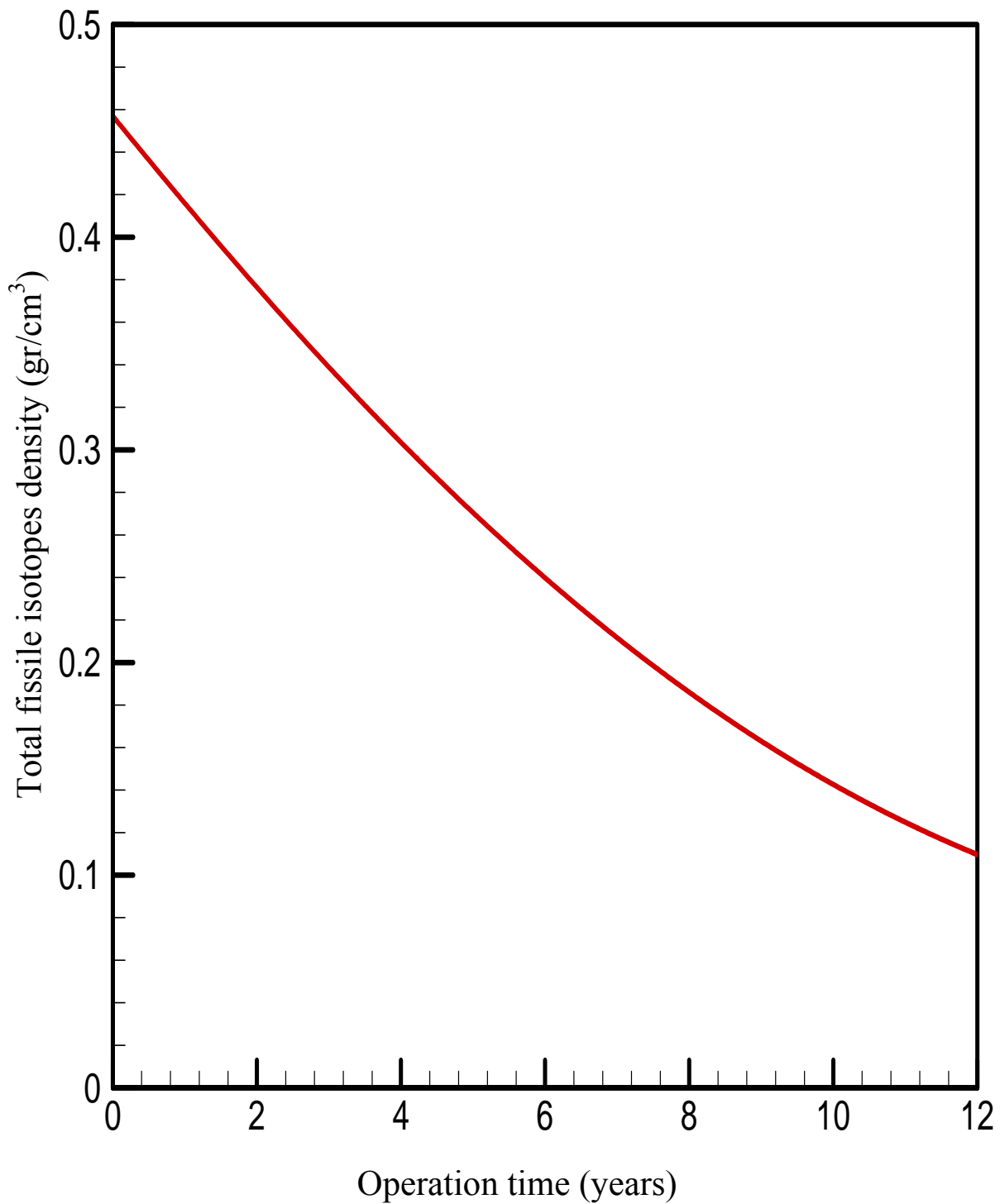

Figure 10. Temporal variation of the accumulated densities of fissile isotopes ($^{235}\text{U} + ^{239}\text{Pu} + ^{241}\text{Pu}$) in the FBNR fuel element

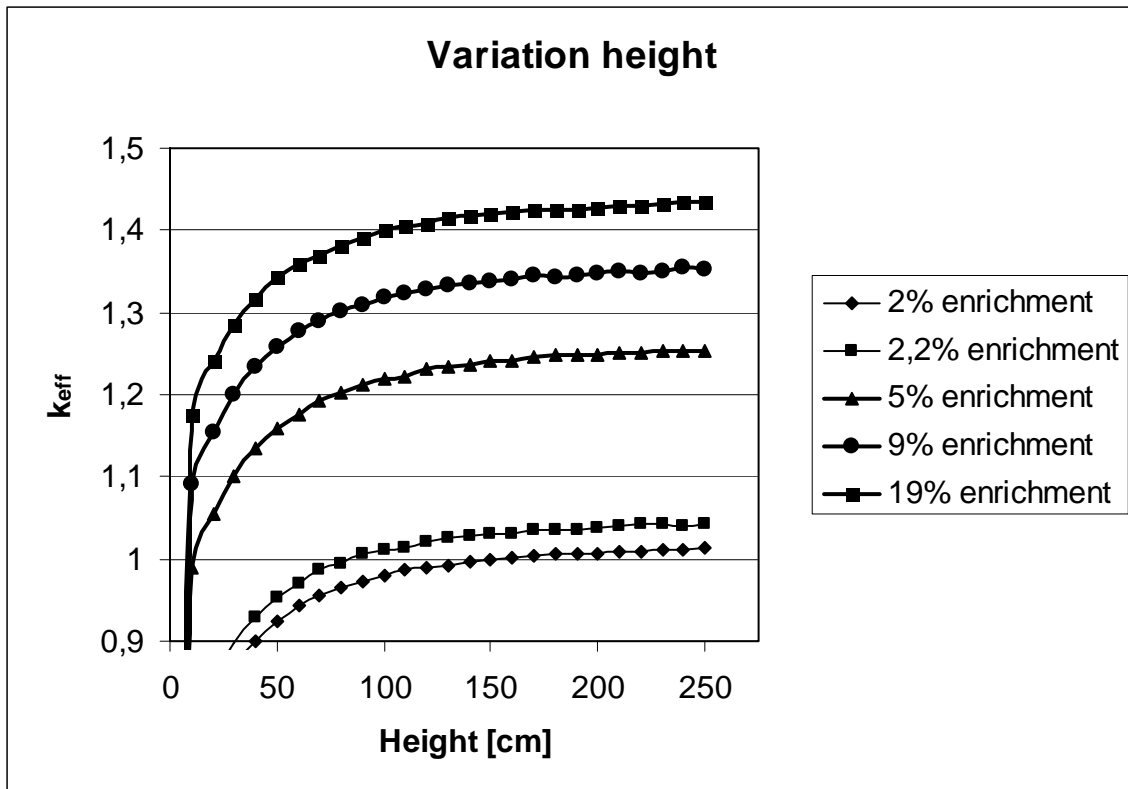

Figure 11. Variation of height for different enrichment values